



Since 1993

www.oversealighting.com

INTEGRATED
SOLAR
LED STREET
LIGHTING



LIGHT CONTROLLER TYPE

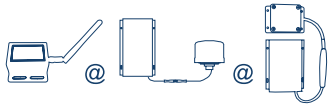

LTE/ LoRaMesh
Wireless Controller

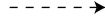

Smart Solar
Street Lighting

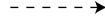

Internet



Smart Cloud Control
System (SCCS)

IOT System - Monitoring System

Monitoring & analyzing data generated from devices connected data such as current device status, energy saving and real time alarm system to eramate stating of current system.

Smart Cloud System

Convenient management of devices connected, to manage power, energy consumption or monitor any failure and damage anywhere through the cloud management system. It provides on demand access to the dashboard via the internet.

Secure System

Login password through system permission settings prevents unauthorized person to operate and keeps the system safer and reliable.

Alarm Warning

Quick and easy maintenance. Multiple alarm notifications for tracking position and fast notification alarm system.

Switch on the Free Working Mode

Save energy consumption and easy to manage the working time of the light according to specific project requirements and situation.



Saving



Compact
Design



Eco
Friendly



Easy
Maintenance



Thief & Damage
Resistance



Remote Area
Application



Option:
Built in Motion
Sensor/ Dimming
Power Mode



Maximum Safety
- No Electric
Shock



LTE

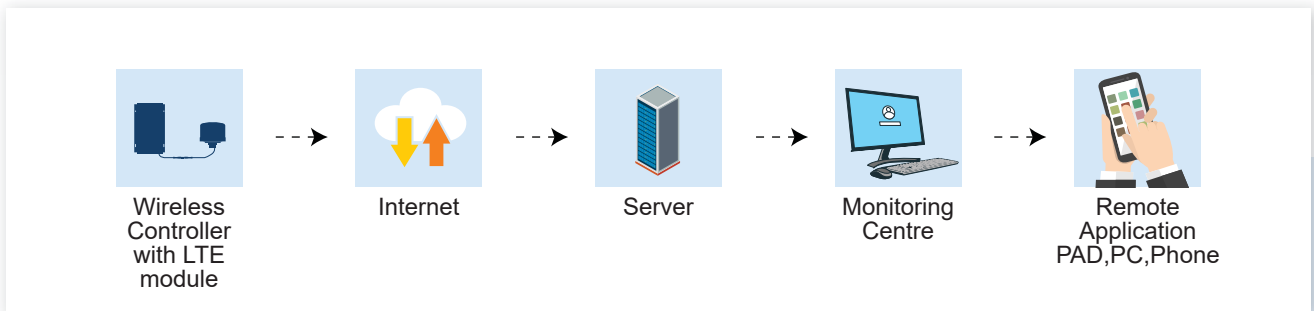

LoRaMesh

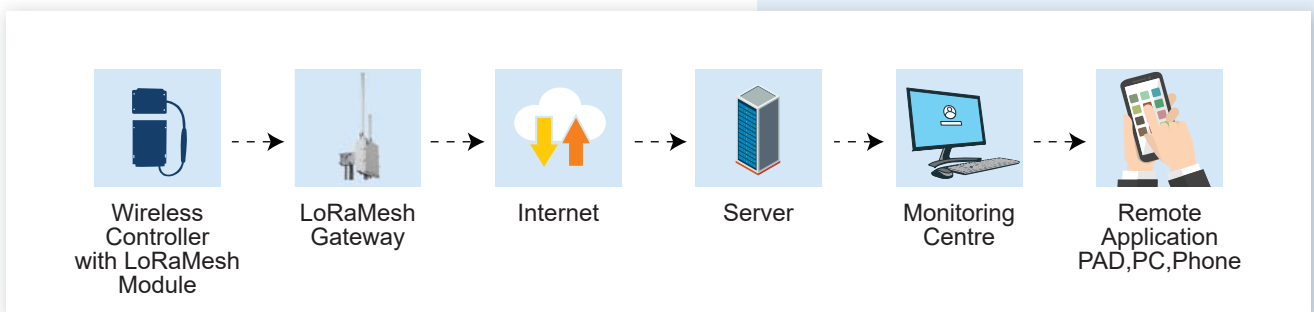

Application Area



Car Park



Park Area



Highway



Residential Street Area



Bike and Pedestrian Path



Bridge Beach Area



INTEGRATED SOLAR

LED STREET LIGHTING



Since 1993

The sun is an in-exhaustive, reliable, non-polluting source of power. Concerns over global climatic change, local air pollution and resource scarcity make photovoltaic (PV) an increasingly attractive energy supply technology. Using solar energy with LEDs instead of CFL provides a very efficient solution. Solar powered outdoor lighting products are ideal for lighting the area in remote locations where the electricity is unavailable or erratic. Even in urban areas, these find great usage to reduce dependency on conventional power and contribute towards green energy. Reliable and long life makes this solution effective in fulfilling our present and future lighting requirements.



**Based on latest
LED technology**



**High efficiency monocrystalline
silicon solar panel**



**Solar powered - No need for any other
power supply source or electrical cabling**



**High end extruded aluminium for LED
module heatsink and extruded aluminium
for enclosure, gives better heat dissipation
and longer life**



CERTIFIED

Safety and Performance, Luminaire,
IEC 60598-2-3,

Luminaires - Part 2-3: Particular requirements -
Luminaires for road and street lighting.

Design, Solar Photovoltaic, (PV)
Module, **IEC 61215-2,**

Terrestrial photovoltaic (PV) modules Design
qualification and type approval Part 2: Test
Procedures. Full type tests include:

- i) **MQT 01 Visual Inspection (including EL imaging)**
- ii) **MQT 19.1 Initial Stabilization**
- iii) **MQT 06.1 Performance at STC**
- iv) **MQT 03 Insulation Test**
- v) **MQT 15 Wet Leakage Current**
- vi) **Sequence C - MQT 10 UV Pre-conditioning Test, 15kWh/m²**
- vii) **Sequence E - MQT 13 Damp Heat 200 hours (deviate 1000h)**
- viii) **MQT 19.2 Final Stabilization**
- ix) **MQT 06.1 Performance at STC**
- x) **MQT 03 Insulation Test**
- xi) **MQT 15 Wet Leakage Current Test**

Note: Test clause viii, ix, x, and xi are conducted after final stabilization

Safety, Rechargeable Deep Cycle
Battery, **IEC 62133-2,**

Secondary cells and batteries containing
alkaline or other non-acid electrolytes Safety
requirements for portable sealed secondary
lithium cells, and for batteries made from them,
for use in portable applications Part 2: Lithium
systems.

Performance, Rechargeable Deep
Cycle Battery, **IEC 62620,**

Secondary cells and batteries containing
alkaline or other non-acid electrolytes -
Secondary lithium cells and batteries for use in
industrial applications.

Safety, Solar Charge Controller,
IEC 62109-1,

Safety of power converters for use in
photovoltaic power systems - Part 1: General
requirements.

Photometric, Luminaire, **IES LM-79,**
Approved Method: Electrical and Photometric
Measurements of Solid-State Lighting
Products.

LED MODULES

NEP LED MODULE



Materials

- Casing material: Extrusion Aluminium
- Lens material: PMMA (Poly Methyl Methacrylate) & Polycarbonate
- Rechargeable Deep Cycle Battery: Performance (500 cycles)
- Battery Lifetime: 5 years

DURA LED MODULE



Materials

- Casing material: Die-Cast Aluminium ADC12
- Lens material: PMMA (Poly Methyl Methacrylate)
- Tempered Glass: Impact Protection IK09
- Ingress Protection: IP66
- Rechargeable Deep Cycle Battery: Performance (500 cycles)
- Battery Lifetime: 5 years



NEP LED Module
High Efficiency LED Chip

High Power LED Chip 5050



DURA LED Module
High Efficiency LED Chip

High Power LED Chip 5050

LED IP68
Modular Optical System

Aluminium Extrusion High Thermal Conductivity

Quickly transfers heat from LED and into the heat sink. It prolongs LED life span.



Monocrystalline Silicon Solar Panel

Excellent Quality Solar Panel

Monocrystalline solar panel in high working efficiency >21%



Timer On / Off Feature

JKC-F model



Solar Charge Controller

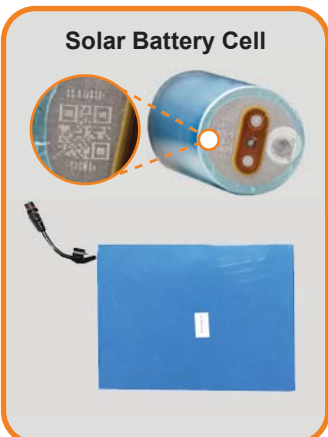

Solar Battery Cell

Lithium Iron Phosphate (LiFePO4) Battery

- OEM Grade A battery cells.
- Each battery comes with a unique QR code, ensuring easier traceability.
- More than 2400 times cycle, full charged can support more than 3 cloudy / rainy days.

IP68 Waterproof Connector

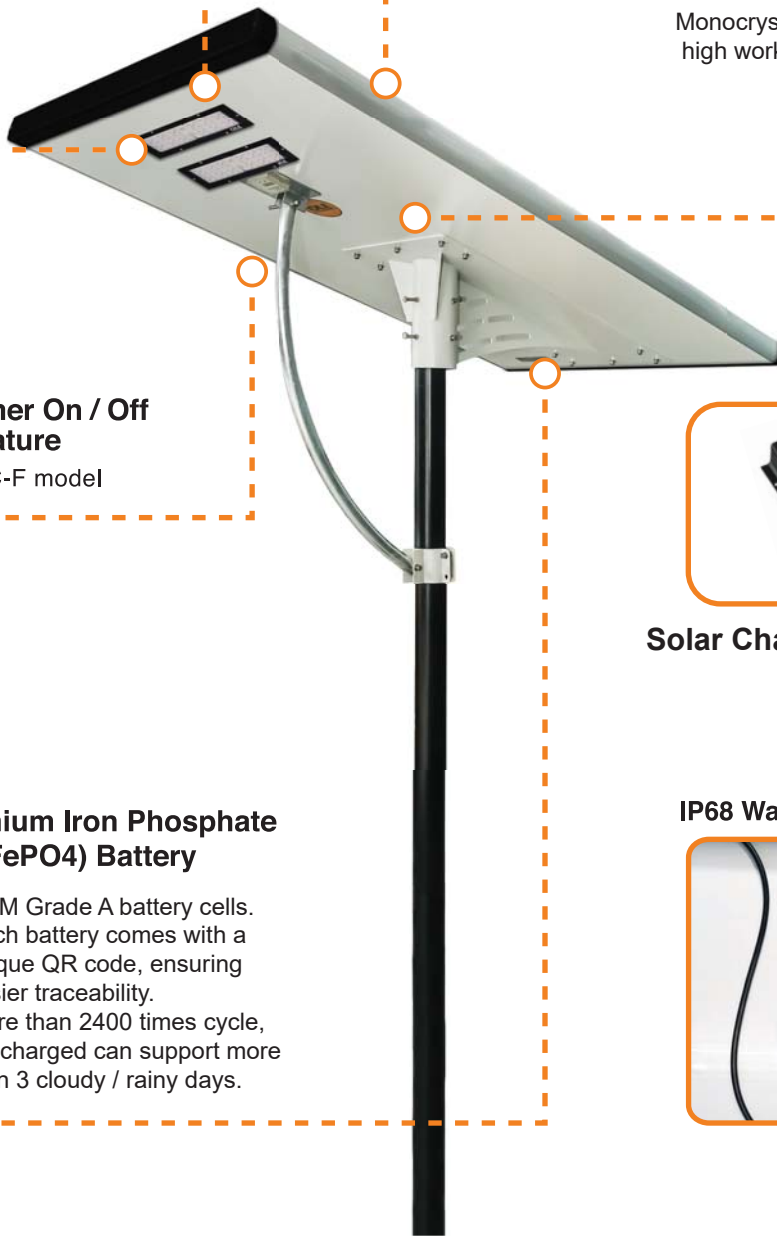

REMOTE CONTROL

Remote Device function as:

- Control light switch
- Adjust light brightness
- Set light working mode
- View and record data/ information:
 - Charge and discharge (Energy and/ or Current and Voltage)
 - State of Charge (SOC) of the battery



Technical Parameters:

Power supply battery	no. 5 (AA) x 2
Power supply voltage	3.0V
Effective distance	8m (infrared remote control), 15m (wireless remote control)
Sleep power consumption	<0.2uA
Normal power consumption	5mA
Transmitting instantaneous power consumption	<50mA
Backlight power consumption	<15mA
Product dimensions	122mm x 60.5mm x 22mm (L x W x H)
Package dimensions	139mm x 77mm x 44mm (L x W x H)
Weight	60grams (without battery)
Automatic power-off time	65 seconds
2000mAH battery setting quantity	30000
Ambient temperature	-25°C ~ 55°C



JKC-K-60W Integrated Solar LED Street Light

(Type A: 3 days autonomy / Type B: 2 days autonomy)



Mounting Recommendation

Height : 6 - 8M
Distance : 20 - 30M

Casing Material

Aluminium Alloy

Dimming System

4H 100% + 2H 60% + 6H 40%

Wire Connector

IP68 Waterproof Connector

Packing & Weight

Product Size : 1750*385*60MM (Luminaire)
(Type A & Type B) : 580*125*320MM (Bracket)
Packing Size : 1830*465*160MM (Luminaire)
(Type A & Type B) : 600*150*340MM (Bracket)

Net Weight

Luminaire : 26KG (Type A) / 21.2KG (Type B)
Bracket : 4KG (Type A) / 3.2KG (Type B)

Gross Weight

Luminaire : 28.5KG (Type A) / 23.7KG (Type B)
Bracket : 4.7KG (Type A) / 3.9KG (Type B)

Mounting Bracket Type

Bracket (Post Top Type)

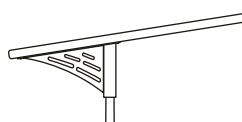

Solar Panel

Type : Imported High Efficiency
Monocrystalline Silicon
Max Power : 36V 135W (Type A & Type B)
Lifetime : 25 Years

Battery

Type : LiFePO4 Battery
Rating : 25.6V 75AH (Type A)
25.6V 60AH (Type B)
Lifetime : 5 Years

LED Lamp

Max Power : 60W
LED Chip : Lumileds 5050
Chip Quantity : 28 PCS
System Efficacy : Typical 175.15 lm/W
Total Lumen : Typical 10,505 lm
Lifetime : 100,000 Hours
Light Distribution Type : Type II (150° x 60°)

Ingress Protection

IP66 Optical Compartment

Charge Time

By Sun : 4.5 Hours

Discharge Time

3 Cloud / Rainy Days / 36 hours (Type A)
2 Cloud / Rainy Days / 24 hours (Type B)

Working Temperature

Range : -25°C ~ +65°C

Colour Temperature

Range : 3000K - 6500K

Light Distribution Curve

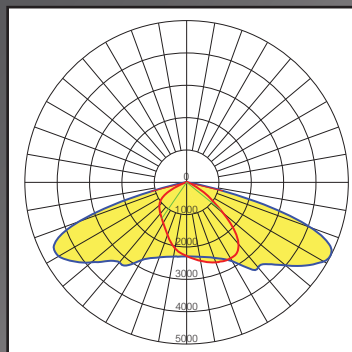

*Optional for GPRS/Zigbee/LoRaWAN Smart System

JKC-K-80W Integrated Solar LED Street Light

(Type A: 3 days autonomy / Type B: 2 days autonomy)



Solar Panel

Type : Imported High Efficiency Monocrystalline Silicon
 Max Power : 36V 135W (Type A & Type B)
 Lifetime : 25 Years

Battery

Type : LiFePO4 Battery
 Rating : 25.6V 90AH (Type A)
 : 25.6V 60AH (Type B)
 Lifetime : 5 Years

LED Lamp

Max Power : 80W
 LED Chip : Lumileds 5050
 Chip Quantity : 56 PCS
 System Efficacy : Typical 185.62 lm/W
 Total Lumen : Typical 14,850 lm
 Lifetime : 100,000 Hours
 Light Distribution Type : Type II (150° x 60°)

Ingress Protection

IP66 Optical Compartment

Charge Time

By Sun : 4.5 Hours

Discharge Time

3 Cloud / Rainy Days / 36 hours (Type A)
 2 Cloud / Rainy Days / 24 hours (Type B)

Working Temperature

Range : -25°C ~ +65°C

Colour Temperature

Range : 3000K - 6500K

Mounting Recommendation

Height : 7 - 8M
 Distance : 23 - 30M

Casing Material

Aluminium Alloy

Dimming System

4H 100% + 2H 60% + 6H 40%

Wire Connector

IP68 Waterproof Connector

Packing & Weight

Product Size : 1750*385*60MM (Luminaire)
 (Type A & Type B) : 580*125*320MM (Bracket)
 Packing Size : 1830*465*160MM (Luminaire)
 (Type A & Type B) : 600*150*340MM (Bracket)

Net Weight

Luminaire : 33KG (Type A) / 38KG (Type B)
 Bracket : 4.5KG (Type A) / 3.2KG (Type B)

Gross Weight

Luminaire : 35.5KG (Type A) / 40.5KG (Type B)
 Bracket : 5.2KG (Type A) / 3.9KG (Type B)

Mounting Bracket Type

Bracket (Post Top Type)

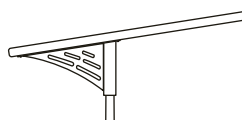

Light Distribution Curve

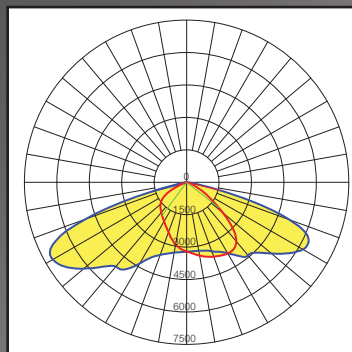

*Optional for GPRS/Zigbee/LoRaWAN Smart System

JKC-K-100W Integrated Solar LED Street Light

(Type A: 3 days autonomy / Type B: 2 days autonomy)



Solar Panel

Type : Imported High Efficiency Monocrystalline Silicon
 Max Power : 36V 210W (Type A & Type B)
 Lifetime : 25 Years

Battery

Type : LiFePO4 Battery
 Rating : 25.6V 120AH (Type A)
 25.6V 90AH (Type B)
 Lifetime : 5 Years

LED Lamp

Max Power : 100W
 LED Chip : Lumileds 5050
 Chip Quantity : 48 PCS
 System Efficacy : Typical 146.76 lm/W
 Total Lumen : Typical 14,735 lm
 Lifetime : 100,000 Hours
 Light Distribution Type : Type II (150° x 60°)

Ingress Protection

IP66 Optical Compartment

Charge Time

By Sun : 4.5 Hours

Discharge Time

3 Cloud / Rainy Days / 36 hours (Type A)
 2 Cloud / Rainy Days / 24 hours (Type B)

Working Temperature

Range : -25°C ~ +65°C

Colour Temperature

Range : 3000K - 6500K

Mounting Recommendation

Height : 8 - 10M
 Distance : 23 - 30M

Casing Material

Aluminium Alloy

Dimming System

4H 100% + 2H 60% + 6H 40%

Wire Connector

IP68 Waterproof Connector

Packing & Weight

Product Size : 1730*585*60MM (Luminaire)
 (Type A & Type B) : 580*125*320MM (Bracket)
 Packing Size : 1810*665*160MM (Luminaire)
 (Type A & Type B) : 600*150*340MM (Bracket)

Net Weight

Luminaire : 38KG (Type A) / 34.7KG (Type B)
 Bracket : 4.5KG (Type A) / 4.2KG (Type B)

Gross Weight

Luminaire : 40.5KG (Type A) / 37.2KG (Type B)
 Bracket : 5.2KG (Type A) / 4.9KG (Type B)

Mounting Bracket Type

Bracket (Post Top Type)

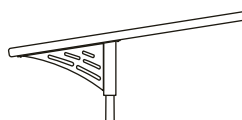

Light Distribution Curve

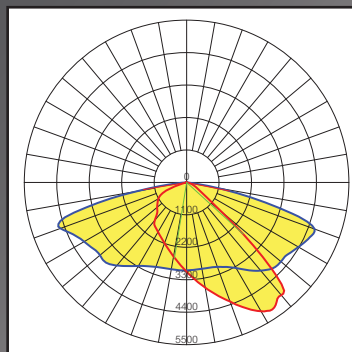

*Optional for GPRS/Zigbee/LoRaWAN Smart System

JKC-K-120W Integrated Solar LED Street Light

(Type A: 3 days autonomy / Type B: 2 days autonomy)



Solar Panel

Type : Imported High Efficiency Monocrystalline Silicon
 Max Power : 36V 210W (Type A & Type B)
 Lifetime : 25 Years

Battery

Type : LiFePO4 Battery
 Rating : 25.6V 135AH (Type A)
 25.6V 90AH (Type B)
 Lifetime : 5 Years

LED Lamp

Max Power : 120W
 LED Chip : Lumileds 5050
 Chip Quantity : 48 PCS
 System Efficacy : Typical 141.05 lm/W
 Total Lumen : Typical 16,968 lm
 Lifetime : 100,000 Hours
 Light Distribution Type : Type II (150° x 60°)

Ingress Protection

IP66 Optical Compartment

Charge Time

By Sun : 4.5 Hours

Discharge Time

3 Cloud / Rainy Days / 36 hours (Type A)
 2 Cloud / Rainy Days / 24 hours (Type B)

Working Temperature

Range : -25°C ~ +65°C

Colour Temperature

Range : 3000K - 6500K

Mounting Recommendation

Height : 8 - 12M
 Distance : 23 - 30M

Casing Material

Aluminium Alloy

Dimming System

4H 100% + 2H 60% + 6H 40%

Wire Connector

IP68 Waterproof Connector

Packing & Weight

Product Size : 1730*585*60MM (Luminaire)
 (Type A & Type B) : 800*400*300MM (Bracket)
 Packing Size : 1810*665*160MM (Luminaire)
 (Type A & Type B) : 850*410*310MM (Bracket)

Net Weight

Luminaire : 43KG (Type A) / 36.9KG (Type B)
 Bracket : 5KG (Type A) / 4.2KG (Type B)

Gross Weight

Luminaire : 45.5KG (Type A) / 39.4KG (Type B)
 Bracket : 5.7KG (Type A) / 4.9KG (Type B)

Mounting Bracket Type

Bracket (Post Top Type)

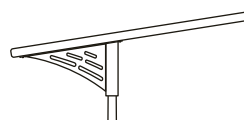

Light Distribution Curve

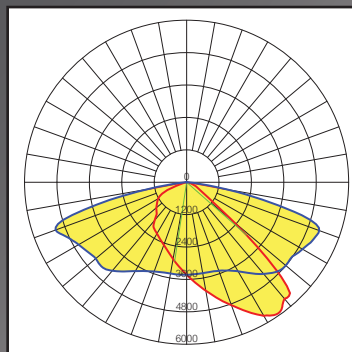

*Optional for GPRS/Zigbee/LoRaWAN Smart System

JKC-K-150W Integrated Solar LED Street Light

(Type A: 3 days autonomy / Type B: 2 days autonomy)



Mounting Recommendation

Height : 9 - 12M
Distance : 30 - 35M

Casing Material

Aluminium Alloy

Dimming System

4H 100% + 2H 60% + 6H 40%

Wire Connector

IP68 Waterproof Connector

Packing & Weight

Product Size : 1720*970*60MM (Luminaire)
(Type A & Type B) : 800*400*300MM (Bracket)
Packing Size : 1800*1050*160MM (Luminaire)
(Type A & Type B) : 850*410*310MM (Bracket)

Net Weight

Luminaire : 60KG (Type A) / 60.5KG (Type B)
Bracket : 5.5KG (Type A) / 6KG (Type B)

Gross Weight

Luminaire : 62.5KG (Type A) / 63KG (Type B)
Bracket : 6.2KG (Type A) / 6.7KG (Type B)

Mounting Bracket Type

Bracket (Post Top Type)

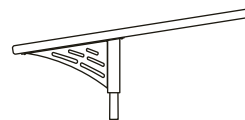

Solar Panel

Type : Imported High Efficiency
Monocrystalline Silicon
Max Power : 36V 310W (Type A & Type B)
Lifetime : 25 Years

Battery

Type : LiFePO4 Battery
Rating : 25.6V 180AH (Type A)
25.6V 120AH (Type B)
Lifetime : 5 Years

LED Lamp

Max Power : 150W
LED Chip : Lumileds 5050
Chip Quantity : 48 PCS
System Efficacy : Typical 133.42 lm/W
Total Lumen : Typical 20,053 lm
Lifetime : 100,000 Hours
Light Distribution Type : Type II (150° x 60°)

Ingress Protection

IP66 Optical Compartment

Charge Time

By Sun : 4.5 Hours

Discharge Time

3 Cloud / Rainy Days / 36 hours (Type A)
2 Cloud / Rainy Days / 24 hours (Type B)

Working Temperature

Range : -25°C ~ +65°C

Colour Temperature

Range : 3000K - 6500K

Light Distribution Curve

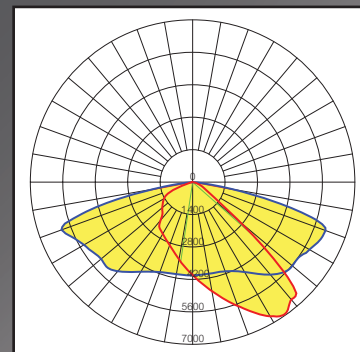

*Optional for GPRS/Zigbee/LoRaWAN Smart System

JKC-K-180W Integrated Solar LED Street Light

(Type A: 3 days autonomy / Type B: 2 days autonomy)



Solar Panel

Type : Imported High Efficiency Monocrystalline Silicon
 Max Power : 36V 310W (Type A & Type B)
 Lifetime : 25 Years

Battery

Type : LiFePO4 Battery
 Rating : 25.6V 210AH (Type A)
 25.6V 135AH (Type B)
 Lifetime : 5 Years

LED Lamp

Max Power : 180W
 LED Chip : Lumileds 5050
 Chip Quantity : 96 PCS
 System Efficacy : Typical 133.42 lm/W
 Total Lumen : Typical 20,053 lm
 Lifetime : 100,000 Hours
 Light Distribution Type : Type II (150° x 60°)

Ingress Protection

IP66 Optical Compartment

Charge Time

By Sun : 4.5 Hours

Discharge Time

3 Cloud / Rainy Days / 36 hours (Type A)
 2 Cloud / Rainy Days / 24 hours (Type B)

Working Temperature

Range : -25°C ~ +65°C

Colour Temperature

Range : 3000K - 6500K

Mounting Recommendation

Height : 9 - 12M
 Distance : 30 - 40M

Casing Material

Aluminium Alloy

Dimming System

4H 100% + 2H 60% + 6H 40%

Wire Connector

IP68 Waterproof Connector

Packing & Weight

Product Size : 1720*970*60MM (Luminaire)
 (Type A & Type B) : 800*400*300MM (Bracket)
 Packing Size : 1800*1050*160MM (Luminaire)
 (Type A & Type B) : 850*410*310MM (Bracket)

Net Weight

Luminaire : 70KG (Type A) / 65KG (Type B)
 Bracket : 7KG (Type A) / 6KG (Type B)
 Gross Weight
 Luminaire : 72.5KG (Type A) / 67.5KG (Type B)
 Bracket : 7.7KG (Type A) / 6.7KG (Type B)

Mounting Bracket Type

Bracket (Post Top Type)

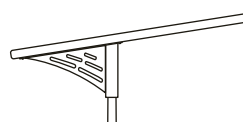

Light Distribution Curve

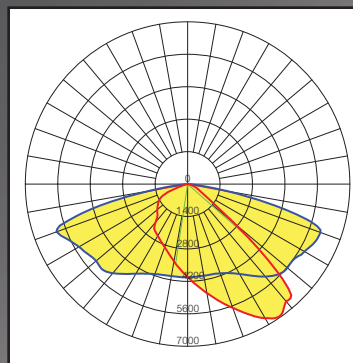

*Optional for GPRS/Zigbee/LoRaWAN Smart System

* Size and weight may have a tolerance of +/-10%

JKC-F-60W Integrated Solar LED Street Light

(Type A: 3 days autonomy / Type B: 2 days autonomy)



Solar Panel

Type : Imported High Efficiency Monocrystalline Silicon
 Max Power : 36V 210W (Type A & Type B)
 Lifetime : 25 Years

Battery

Type : LiFePO4 Battery
 Rating : 25.6V 90AH (Type A)
 25.6V 60AH (Type B)
 Lifetime : 5 Years

LED Lamp

Max Power : 60W
 LED Chip : Lumileds 5050
 Chip Quantity : 28 PCS
 System Efficacy : Typical 175.15 lm/W
 Total Lumen : Typical 10,505 lm
 Lifetime : 100,000 Hours
 Light Distribution Type : Type II (150° x 60°)

Ingress Protection

IP66 Optical Compartment

Charge Time

By Sun : 4.5 Hours

Discharge Time

3 Cloud / Rainy Days / 36 hours (Type A)
 2 Cloud / Rainy Days / 24 hours (Type B)

Working Temperature

Range : -25°C ~ +65°C

Colour Temperature

Range : 3000K - 6500K

Mounting Recommendation

Height : 7 - 8M
 Distance : 22 - 30M

Casing Material

Aluminium Alloy

Dimming System

12H 100%

Wire Connector

IP68 Waterproof Connector

Packing & Weight

Product Size : 1730*605*60MM (Luminaire)
 (Type A & Type B) : 800*800*300MM (Bracket)
 Packing Size : 1810*685*160MM (Luminaire)
 (Type A & Type B) : 850*810*310MM (Bracket)

Net Weight

Luminaire : 38KG (Type A) / 34KG (Type B)
 Bracket : 4.5KG (Type A & Type B)
 Gross Weight
 Luminaire : 40.5KG (Type A) / 36.5KG (Type B)
 Bracket : 5.2KG (Type A & Type B)

Mounting Bracket Type

Bracket (Post Top Type)

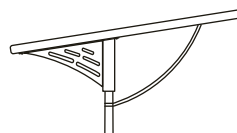

Light Distribution Curve

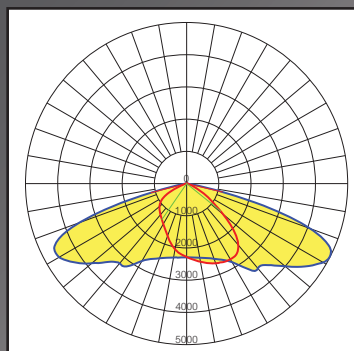

*Optional for GPRS/Zigbee/LoRaWAN Smart System

JKC-F-80W Integrated Solar LED Street Light

(Type A: 3 days autonomy / Type B: 2 days autonomy)



Solar Panel

Type : Imported High Efficiency Monocrystalline Silicon
 Max Power : 36V 210W (Type A & Type B)
 Lifetime : 25 Years

Battery

Type : LiFePO4 Battery
 Rating : 25.6V 150AH (Type A)
 25.6V 90AH (Type B)
 Lifetime : 5 Years

LED Lamp

Max Power : 80W
 LED Chip : Lumileds 5050
 Chip Quantity : 48 PCS
 System Efficacy : Typical 185.62 lm/W
 Total Lumen : Typical 14,850 lm
 Lifetime : 100,000 Hours
 Light Distribution Type : Type II (150° x 60°)

Ingress Protection

IP66 Optical Compartment

Charge Time

By Sun : 4.5 Hours

Discharge Time

3 Cloud / Rainy Days / 36 hours (Type A)
 2 Cloud / Rainy Days / 24 hours (Type B)

Working Temperature

Range : -25°C ~ +65°C

Colour Temperature

Range : 3000K - 6500K

Mounting Recommendation

Height : 7 - 8M
 Distance : 23 - 34M

Casing Material

Aluminium Alloy

Dimming System

12H 100%

Wire Connector

IP68 Waterproof Connector

Packing & Weight

Product Size : 1730*605*60MM (Luminaire)
 (Type A & Type B) : 800*800*300MM (Bracket)
 Packing Size : 1810*685*160MM (Luminaire)
 (Type A & Type B) : 850*810*310MM (Bracket)

Net Weight

Luminaire : 45KG (Type A) / 38KG (Type B)
 Bracket : 5KG (Type A) / 4.5KG (Type B)
 Gross Weight
 Luminaire : 47.5KG (Type A) / 40.5KG (Type B)
 Bracket : 5.7KG (Type A) / 5.2KG (Type B)

Mounting Bracket Type

Bracket (Post Top Type)

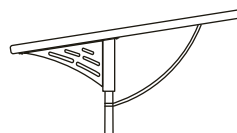

Light Distribution Curve

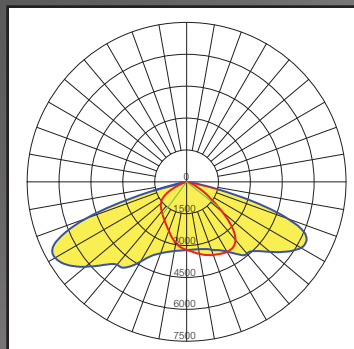

*Optional for GPRS/Zigbee/LoRaWAN Smart System

JKC-F-100W Integrated Solar LED Street Light

(Type A: 3 days autonomy / Type B: 2 days autonomy)



Solar Panel

Type : Imported High Efficiency Monocrystalline Silicon
 Max Power : 36V 320W (Type A & Type B)
 Lifetime : 25 Years

Battery

Type : LiFePO4 Battery
 Rating : 25.6V 180AH (Type A)
 25.6V 120AH (Type B)
 Lifetime : 5 Years

LED Lamp

Max Power : 100W
 LED Chip : Lumileds 5050
 Chip Quantity : 48 PCS
 System Efficacy : Typical 146.76 lm/W
 Total Lumen : Typical 14,735 lm
 Lifetime : 100,000 Hours
 Light Distribution Type : Type II (150° x 60°)

Ingress Protection

IP66 Optical Compartment

Charge Time

By Sun : 4.5 Hours

Discharge Time

3 Cloud / Rainy Days / 36 hours (Type A)
 2 Cloud / Rainy Days / 24 hours (Type B)

Working Temperature

Range : -25°C ~ +65°C

Colour Temperature

Range : 3000K - 6500K

Mounting Recommendation

Height : 8 - 10M
 Distance : 23 - 34M

Casing Material

Aluminium Alloy

Dimming System

12H 100%

Wire Connector

IP68 Waterproof Connector

Packing & Weight

Product Size : 1720*970*60MM (Luminaire)
 (Type A & Type B) : 800*800*300MM (Bracket)
 Packing Size : 1800*1050*160MM (Luminaire)
 (Type A & Type B) : 850*810*310MM (Bracket)

Net Weight

Luminaire : 60KG (Type A) / 45KG (Type B)
 Bracket : 5KG (Type A & Type B)
 Gross Weight
 Luminaire : 62.5KG (Type A) / 47.5KG (Type B)
 Bracket : 5.7KG (Type A & Type B)

Mounting Bracket Type

Bracket (Post Top Type)

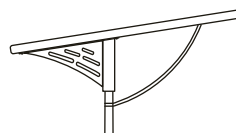

Light Distribution Curve

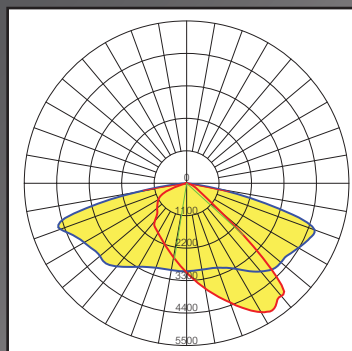

*Optional for GPRS/Zigbee/LoRaWAN Smart System

JKC-F-120W Integrated Solar LED Street Light

(Type A: 3 days autonomy / Type B: 2 days autonomy)



Solar Panel

Type : Imported High Efficiency Monocrystalline Silicon
 Max Power : 36V 320W (Type A & Type B)
 Lifetime : 25 Years

Battery

Type : LiFePO4 Battery
 Rating : 25.6V 210AH (Type A)
 25.6V 150AH (Type B)
 Lifetime : 5 Years

LED Lamp

Max Power : 120W
 LED Chip : Lumileds 5050
 Chip Quantity : 48 PCS
 System Efficacy : Typical 138.9 lm/W
 Total Lumen : Typical 16,751 lm
 Lifetime : 100,000 Hours
 Light Distribution Type : Type II (150° x 60°)

Ingress Protection

IP66 Optical Compartment

Charge Time

By Sun : 4.5 Hours

Discharge Time

3 Cloud / Rainy Days / 36 hours (Type A)
 2 Cloud / Rainy Days / 24 hours (Type B)

Working Temperature

Range : -25°C ~ +65°C

Colour Temperature

Range : 3000K - 6500K

Mounting Recommendation

Height : 9 - 12M
 Distance : 23 - 34M

Casing Material

Aluminium Alloy

Dimming System

12H 100%

Wire Connector

IP68 Waterproof Connector

Packing & Weight

Product Size : 1720*975*60MM (Type A Luminaire)
 : 1720*970*60MM (Type B Luminaire)
 (Bracket) : 800*800*300MM (Type A & Type B)
 Packing Size : 1800*1055*160MM (Type A Luminaire)
 : 1800*1050*160MM (Type B Luminaire)
 (Bracket) : 850*810*310MM (Type A & Type B)

Net Weight
 Luminaire : 65KG (Type A) / 47KG (Type B)
 Bracket : 8.5KG (Type A) / 5KG (Type B)
 Gross Weight
 Luminaire : 67.5KG (Type A) / 49.5KG (Type B)
 Bracket : 9.2KG (Type A) / 5.7KG (Type B)

Mounting Bracket Type

Bracket (Post Top Type)

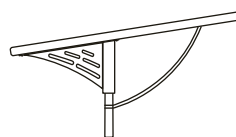

Light Distribution Curve

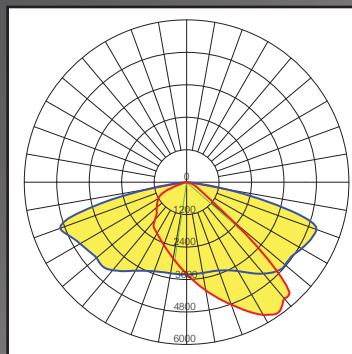

*Optional for GPRS/Zigbee/LoRaWAN Smart System

* Size and weight may have a tolerance of +-10%

JKC-F-150W Integrated Solar LED Street Light

(Type A: 3 days autonomy / Type B: 2 days autonomy)



Solar Panel

Type : Imported High Efficiency Monocrystalline Silicon
 Max Power : 36V 400W (Type A & Type B)
 Lifetime : 25 Years

Battery

Type : LiFePO4 Battery
 Rating : 25.6V 270AH (Type A)
 25.6V 180AH (Type B)
 Lifetime : 5 Years

LED Lamp

Max Power : 150W
 LED Chip : Lumileds 5050
 Chip Quantity : 48 PCS
 System Efficacy : Typical 132.54 lm/W
 Total Lumen : Typical 19,947 lm
 Lifetime : 100,000 Hours
 Light Distribution Type : Type II (150° x 60°)

Ingress Protection

IP66 Optical Compartment

Charge Time

By Sun : 4.5 Hours

Discharge Time

3 Cloud / Rainy Days / 36 hours (Type A)
 2 Cloud / Rainy Days / 24 hours (Type B)

Working Temperature

Range : -30°C ~ +70°C

Colour Temperature

Range : 3000K - 6500K

Mounting Recommendation

Height : 9 - 12M
 Distance : 35 - 38M

Casing Material

Aluminium Alloy

Dimming System

12H 100%

Wire Connector

IP68 Waterproof Connector

Packing & Weight

Product Size : 2150*975*60MM (Type A Luminaire)
 : 2150*972*60MM (Type B Luminaire)
 (Bracket) : 800*800*300MM (Type A & Type B)
 Packing Size : 2230*1055*160MM (Type A Luminaire)
 : 2230*1052*160MM (Type B Luminaire)
 (Bracket) : 850*810*310MM (Type A & Type B)

Net Weight
 Luminaire : 75KG (Type A) / 70KG (Type B)
 Bracket : 8.5KG (Type A) / 7KG (Type B)
 Gross Weight
 Luminaire : 77.5KG (Type A) / 72.5KG (Type B)
 Bracket : 9.2KG (Type A) / 7.7KG (Type B)

Mounting Bracket Type

Bracket (Post Top Type)

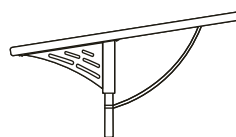

Light Distribution Curve

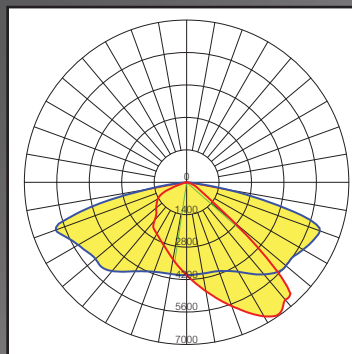

*Optional for GPRS/Zigbee/LoRaWAN Smart System

* Size and weight may have a tolerance of +-10%

JKC-F-180W Integrated Solar LED Street Light

(Type A: 3 days autonomy / Type B: 2 days autonomy)



Solar Panel

Type : Imported High Efficiency Monocrystalline Silicon
 Max Power : 36V 480W (Type A & Type B)
 Lifetime : 25 Years

Battery

Type : LiFePO4 Battery
 Rating : 25.6V 315AH (Type A)
 25.6V 210AH (Type B)
 Lifetime : 5 Years

LED Lamp

Max Power : 180W
 LED Chip : Lumileds 5050
 Chip Quantity : 96 PCS
 System Efficacy : Typical 133.42 lm/W
 Total Lumen : Typical 20,053 lm
 Lifetime : 100,000 Hours
 Light Distribution Type : Type II (150° x 60°)

Ingress Protection

IP66 Optical Compartment

Charge Time

By Sun : 4.5 Hours

Discharge Time

3 Cloud / Rainy Days / 36 hours (Type A)
 2 Cloud / Rainy Days / 24 hours (Type B)

Working Temperature

Range : -30°C ~ +70°C

Colour Temperature

Range : 3000K - 6500K

Mounting Recommendation

Height : 9 - 12M
 Distance : 35 - 38M

Casing Material

Aluminium Alloy

Dimming System

12H 100%

Wire Connector

IP68 Waterproof Connector

Packing & Weight

Product Size : 2446*975*60MM (Type A Luminaire)
 : 2016*1100*60MM (Type B Luminaire)
 (Bracket) : 800*800*300MM (Bracket)
 Packing Size : 2526*1055*160MM (Type A Luminaire)
 : 2096*1180*160MM (Type B Luminaire)
 (Bracket) : 850*810*310MM (Bracket)

Net Weight

Luminaire : 85KG (Type A) / 82KG (Type B)
 Bracket : 8.5KG (Type A) / 7.5KG (Type B)

Gross Weight

Luminaire : 87.5KG (Type A) / 84.5KG (Type B)
 Bracket : 9.2KG (Type A) / 8.2KG (Type B)

Mounting Bracket Type

Bracket (Post Top Type)

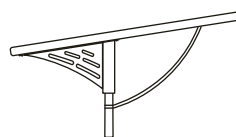

Light Distribution Curve

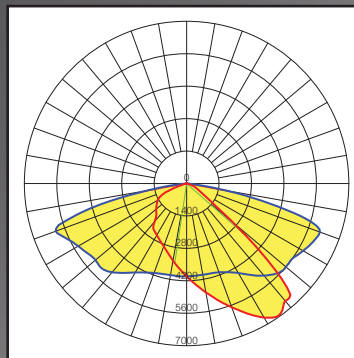

*Optional for GPRS/Zigbee/L0RaWAN Smart System

* Size and weight may have a tolerance of +/-10%



NEP LED Module
High Efficiency LED Chip
High Power LED Chip 5050



DURA LED Module
High Efficiency LED Chip
High Power LED Chip 5050

Adjustable LED Module Angle

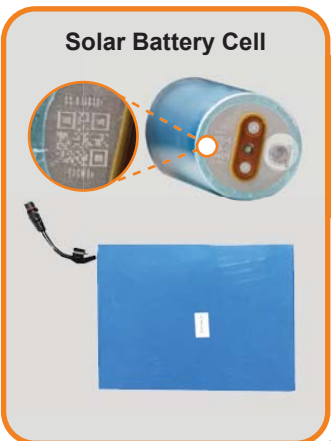

Solar Battery Cell

Lithium Iron Phosphate (LiFePO4) Battery

- OEM Grade A battery cells.
- Each battery comes with a unique QR code, ensuring easier traceability.
- More than 2400 times cycle, full charged can support more than 3 cloudy / rainy days.

LED IP68 Modular Optical System

Aluminium Extrusion High Thermal Conductivity

Quickly transfer heat away from LED and into the heat sink. It prolong LED life span.



Monocrystalline Silicon Solar Panel

Excellent Quality Solar Panel

Monocrystalline solar panel in high working efficiency >21%



Solar Charge Controller

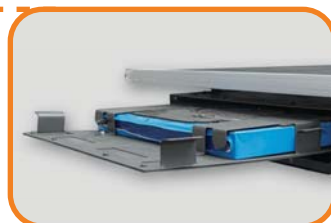

Easy Removable Battery

IP68 Waterproof Connector



JKC-R-40W Integrated Solar LED Floodlight/ Street Light

(2 days autonomy)



Solar Panel

Type : Imported High Efficiency Monocrystalline Silicon
 Max Power : 36V 70W (Type B)
 Lifetime : 25 Years

Battery

Type : LiFePO4 Battery
 Rating : 25.6V 30AH
 Lifetime : 5 Years

LED Lamp

Max Power : 40W
 LED Chip : Lumileds 5050
 Chip Quantity : 28 PCS
 System Efficacy : Typical 175.15 lm/W
 Total Lumen : Typical 7,000 lm
 Lifetime : 100,000 Hours

Ingress Protection

IP66 Optical Compartment

Charge Time

By Sun : 4.5 Hours

Discharge Time

2 Cloud / Rainy Days / 24 hours

Working Temperature

Range : -25°C ~ +65°C

Colour Temperature

Range : 3000K - 6500K

Mounting Recommendation

Height : 4 - 6M
 Distance : 16 - 25M

Casing Material

Aluminium Alloy

Dimming System

4H 100% + 2H 60% + 6H 40%

Wire Connector

IP68 Waterproof Connector

Packing & Weight

Product Size : 975*670*125MM (Luminaire)
 (Type A & Type B) : 846*650*120.5MM (Bracket)
 Packing Size : 1055*750*225MM (Luminaire)
 (Type A & Type B) : 1900*770*170MM (Bracket)

Net Weight

Luminaire : 36.5KG (Type A) / 24.2KG (Type B)
 Bracket : 3.2KG (Type A & Type B)
 Gross Weight
 Luminaire : 39KG (Type A) / 26.7KG (Type B)
 Bracket : 3.9KG (Type A & Type B)

Mounting Bracket Type

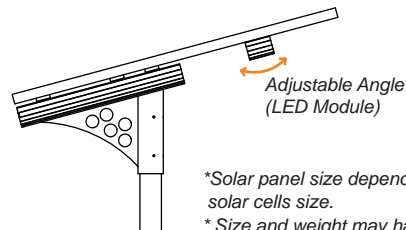

*Solar panel size depends on available solar cells size.
 * Size and weight may have a tolerance of +-10%

Light Distribution Curve

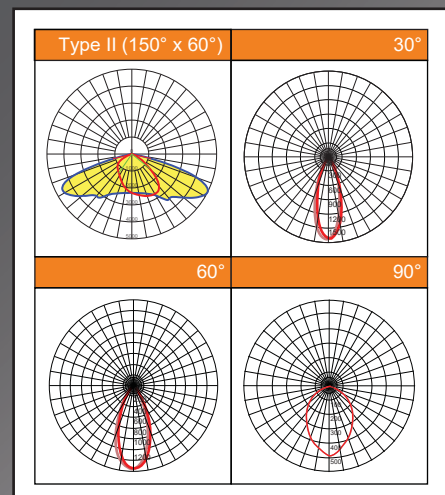

*Optional for GPRS/Zigbee/LoRaWAN Smart System

* Size and weight may have a tolerance of +-10%

JKC-R-60W Integrated Solar LED Floodlight/ Street Light

(Type A: 3 days autonomy / Type B: 2 days autonomy)



Casing Material

Aluminium Alloy

Dimming System

4H 100% + 2H 60% + 6H 40%

Wire Connector

IP68 Waterproof Connector

Packing & Weight

Product Size : 1190*670*125MM (Luminaire)
 (Type A & Type B) : 846*650*120.5MM (Bracket)
 Packing Size : 1270*750*225MM (Luminaire)
 (Type A & Type B) : 1900*770*170MM (Bracket)

Net Weight

Luminaire : 40KG (Type A) / 36.5KG (Type B)
 Bracket : 3.2KG (Type A & Type B)
 Gross Weight
 Luminaire : 42.5KG (Type A) / 39KG (Type B)
 Bracket : 3.9KG (Type A & Type B)

Mounting Bracket Type

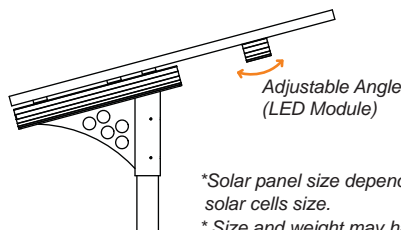

*Solar panel size depends on available solar cells size.
 * Size and weight may have a tolerance of +-10%

Solar Panel

Type : Imported High Efficiency Monocrystalline Silicon
 Max Power : 36V 135W (Type A & Type B)
 Lifetime : 25 Years

Battery

Type : LiFePO4 Battery
 Rating : 25.6V 75AH (Type A)
 25.6V 60AH (Type B)
 Lifetime : 5 Years

LED Lamp

Max Power : 60W
 LED Chip : Lumileds 5050
 Chip Quantity : 28 PCS
 System Efficacy : Typical 175.15 lm/W
 Total Lumen : Typical 10,505 lm
 Lifetime : 100,000 Hours

Ingress Protection

IP66 Optical Compartment

Charge Time

By Sun : 4.5 Hours

Discharge Time

3 Cloud / Rainy Days / 36 hours (Type A)
 2 Cloud / Rainy Days / 24 hours (Type B)

Working Temperature

Range : -25°C ~ +65°C

Colour Temperature

Range : 3000K - 6500K

Mounting Recommendation

Height : 6 - 8M
 Distance : 23 - 30M

Light Distribution Curve

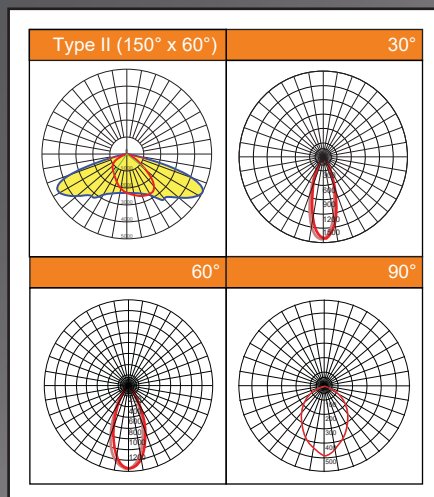

*Optional for GPRS/Zigbee/L0RaWAN Smart System

* Size and weight may have a tolerance of +-10%

JKC-R-80W Integrated Solar LED Floodlight/ Street Light

(Type A: 3 days autonomy / Type B: 2 days autonomy)



Casing Material

Aluminium Alloy

Dimming System

4H 100% + 2H 60% + 6H 40%

Wire Connector

IP68 Waterproof Connector

Packing & Weight

Product Size : 1190*670*125MM (Luminaire)
 (Type A & Type B) : 846*650*120.5MM (Bracket)
 Packing Size : 1270*750*225MM (Luminaire)
 (Type A & Type B) : 1900*770*170MM (Bracket)

Net Weight

Luminaire : 60.5KG (Type A) / 37.7KG (Type B)
 Bracket : 4.2KG (Type A & Type B)
 Gross Weight
 Luminaire : 63KG (Type A) / 40.2KG (Type B)
 Bracket : 4.9KG (Type A & Type B)

Mounting Bracket Type

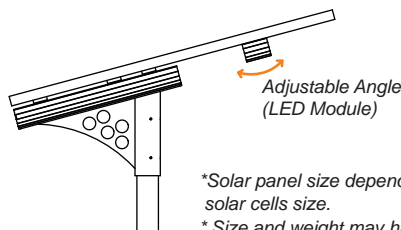

Solar Panel

Type : Imported High Efficiency Monocrystalline Silicon
 Max Power : 36V 135W (Type A & Type B)
 Lifetime : 25 Years

Battery

Type : LiFePO4 Battery
 Rating : 25.6V 90AH (Type A)
 25.6V 60AH (Type B)
 Lifetime : 5 Years

LED Lamp

Max Power : 80W
 LED Chip : Lumileds 5050
 Chip Quantity : 56 PCS
 System Efficacy : Typical 185.62 lm/W
 Total Lumen : Typical 14,850 lm
 Lifetime : 100,000 Hours

Ingress Protection

IP66 Optical Compartment

Charge Time

By Sun : 4.5 Hours

Discharge Time

3 Cloud / Rainy Days / 36 hours (Type A)
 2 Cloud / Rainy Days / 24 hours (Type B)

Working Temperature

Range : -25°C ~ +65°C

Colour Temperature

Range : 3000K - 6500K

Mounting Recommendation

Height : 8 - 10M
 Distance : 23 - 30M

Light Distribution Curve

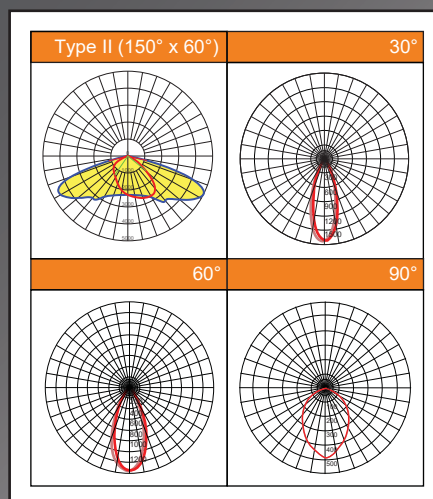

*Optional for GPRS/Zigbee/L0RaWAN Smart System

* Size and weight may have a tolerance of +-10%

JKC-R-100W Integrated Solar LED Floodlight/ Street Light

(Type A: 3 days autonomy / Type B: 2 days autonomy)



Casing Material

Aluminium Alloy

Dimming System

4H 100% + 2H 60% + 6H 40%

Wire Connector

IP68 Waterproof Connector

Packing & Weight

Product Size : 1650*680*125MM (Luminaire)
 (Type A & Type B) : 846*650*120.5MM (Bracket)
 Packing Size : 1730*760*225MM (Luminaire)
 (Type A & Type B) : 1900*770*170MM (Bracket)

Net Weight

Luminaire : 68KG (Type A) / 40KG (Type B)
 Bracket : 4.2KG (Type A & Type B)
 Gross Weight
 Luminaire : 70.5KG (Type A) / 42.5KG (Type B)
 Bracket : 4.9KG (Type A & Type B)

Mounting Bracket Type

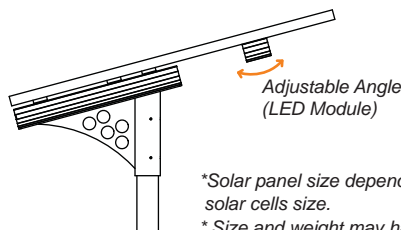

Solar Panel

Type : Imported High Efficiency Monocrystalline Silicon
 Max Power : 36V 210W (Type A & Type B)
 Lifetime : 25 Years

Battery

Type : LiFePO4 Battery
 Rating : 25.6V 120AH (Type A)
 25.6V 90AH (Type B)
 Lifetime : 5 Years

LED Lamp

Max Power : 100W
 LED Chip : Lumileds 5050
 Chip Quantity : 48 PCS
 System Efficacy : Typical 146.76 lm/W
 Total Lumen : Typical 14,735 lm
 Lifetime : 100,000 Hours

Ingress Protection

IP66 Optical Compartment

Charge Time

By Sun : 4.5 Hours

Discharge Time

3 Cloud / Rainy Days / 36 hours (Type A)
 2 Cloud / Rainy Days / 24 hours (Type B)

Working Temperature

Range : -25°C ~ +65°C

Colour Temperature

Range : 3000K - 6500K

Mounting Recommendation

Height : 9 - 12M
 Distance : 23 - 34M

Light Distribution Curve

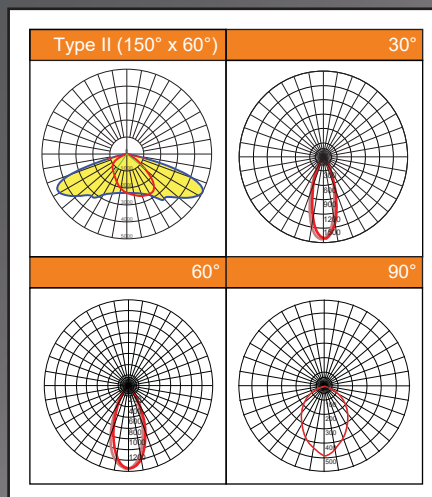

*Optional for GPRS/Zigbee/L0RaWAN Smart System

* Size and weight may have a tolerance of +-10%

JKC-R-120W Integrated Solar LED Floodlight/ Street Light

(Type A: 3 days autonomy / Type B: 2 days autonomy)



Casing Material

Aluminium Alloy

Dimming System

4H 100% + 2H 60% + 6H 40%

Wire Connector

IP68 Waterproof Connector

Packing & Weight

Product Size : 1650*680*125MM (Luminaire)
 (Type A & Type B) : 846*650*120.5MM (Bracket)
 Packing Size : 1730*760*225MM (Luminaire)
 (Type A & Type B) : 1900*770*170MM (Bracket)

Net Weight

Luminaire : 72KG (Type A) / 63.5KG (Type B)
 Bracket : 6KG (Type A & Type B)
 Gross Weight
 Luminaire : 74.5KG (Type A) / 66KG (Type B)
 Bracket : 6.7KG (Type A & Type B)

Mounting Bracket Type

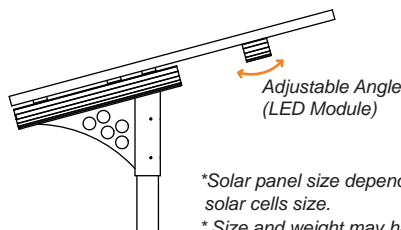

Solar Panel

Type : Imported High Efficiency Monocrystalline Silicon
 Max Power : 36V 210W (Type A & Type B)
 Lifetime : 25 Years

Battery

Type : LiFePO4 Battery
 Rating : 25.6V 135AH (Type A)
 25.6V 90AH (Type B)
 Lifetime : 5 Years

LED Lamp

Max Power : 120W
 LED Chip : Lumileds 5050
 Chip Quantity : 48 PCS
 System Efficacy : Typical 141.05 lm/W
 Total Lumen : Typical 16,968 lm
 Lifetime : 100,000 Hours

Ingress Protection

IP66 Optical Compartment

Charge Time

By Sun : 4.5 Hours

Discharge Time

3 Cloud / Rainy Days / 36 hours (Type A)
 2 Cloud / Rainy Days / 24 hours (Type B)

Working Temperature

Range : -30°C ~ +70°C

Colour Temperature

Range : 3000K - 6500K

Mounting Recommendation

Height : 9 - 12M
 Distance : 30 - 38M

Light Distribution Curve

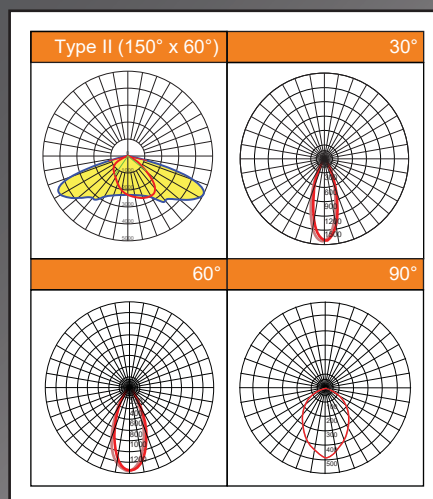

*Optional for GPRS/Zigbee/L0RaWAN Smart System

* Size and weight may have a tolerance of +-10%

JKC-R-150W Integrated Solar LED Floodlight/ Street Light

(Type A: 3 days autonomy / Type B: 2 days autonomy)



Casing Material

Aluminium Alloy

Dimming System

4H 100% + 2H 60% + 6H 40%

Wire Connector

IP68 Waterproof Connector

Packing & Weight

Product Size : 1650*990*125MM (Luminaire)
 (Type A & Type B) : 846*650*120.5MM (Bracket)
 Packing Size : 1730*1070*225MM (Luminaire)
 (Type A & Type B) : 1900*770*170MM (Bracket)

Net Weight

Luminaire : 81.5KG (Type A) / 68KG (Type B)
 Bracket : 6KG (Type A & Type B)
 Gross Weight
 Luminaire : 84KG (Type A) / 70.5KG (Type B)
 Bracket : 6.7KG (Type A & Type B)

Mounting Bracket Type

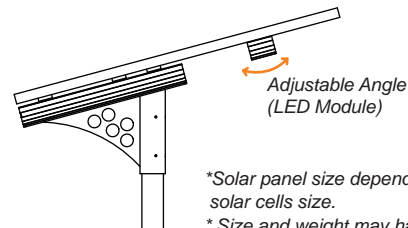

Solar Panel

Type : Imported High Efficiency Monocrystalline Silicon
 Max Power : 36V 310W (Type A & Type B)
 Lifetime : 25 Years

Battery

Type : LiFePO4 Battery
 Rating : 25.6V 180AH (Type A)
 25.6V 120AH (Type B)
 Lifetime : 5 Years

LED Lamp

Max Power : 150W
 LED Chip : Lumileds 5050
 Chip Quantity : 48 PCS
 System Efficacy : Typical 133.42 lm/W
 Total Lumen : Typical 20,053 lm
 Lifetime : 100,000 Hours

Ingress Protection

IP66 Optical Compartment

Charge Time

By Sun : 4.5 Hours

Discharge Time

3 Cloud / Rainy Days / 36 hours (Type A)
 2 Cloud / Rainy Days / 24 hours (Type B)

Working Temperature

Range : -30°C ~ +70°C

Colour Temperature

Range : 3000K - 6500K

Mounting Recommendation

Height : 9 - 12M
 Distance : 35 - 40M

Light Distribution Curve

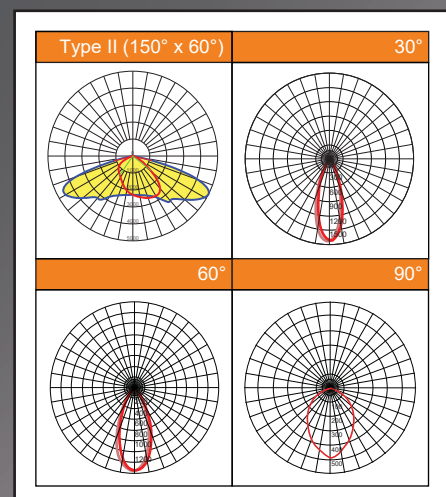

*Optional for GPRS/Zigbee/L0RaWAN Smart System

* Size and weight may have a tolerance of +-10%

JKC-L-40W Integrated Solar LED Floodlight/ Street Light

(2 days autonomy)



Casing Material

Aluminium Alloy

Dimming System

12H 100%

Wire Connector

IP68 Waterproof Connector

Packing & Weight

Product Size : 975*670*125MM (Luminaire)
 (Type A & Type B) : 601.5*540*85.3MM (Bracket)
 Packing Size : 1055*750*225MM (Luminaire)
 (Type A & Type B) : 1000*650*180MM (Bracket)

Net Weight

Luminaire : 41KG (Type A) / 36KG (Type B)
 Bracket : 4.5KG (Type A & Type B)
 Gross Weight
 Luminaire : 43.5KG (Type A) / 38.5KG (Type B)
 Bracket : 5.2KG (Type A & Type B)

Mounting Bracket Type

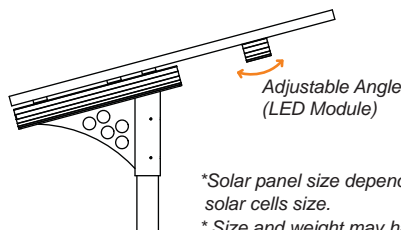

Solar Panel

Type : Imported High Efficiency Monocrystalline Silicon
 Max Power : 36V 110W (Type B)
 Lifetime : 25 Years

Battery

Type : LiFePO4 Battery
 Rating : 25.6V 45AH
 Lifetime : 5 Years

LED Lamp

Max Power : 40W
 LED Chip : Lumileds 5050
 Chip Quantity : 28 PCS
 System Efficacy : Typical 175.15 lm/W
 Total Lumen : Typical 7,000 lm
 Lifetime : 100,000 Hours

Ingress Protection

IP66 Optical Compartment

Charge Time

By Sun : 4.5 Hours

Discharge Time

2 Cloud / Rainy Days / 24 hours

Working Temperature

Range : -25°C ~ +65°C

Colour Temperature

Range : 3000K - 6500K

Mounting Recommendation

Height : 4 - 6M
 Distance : 16 - 25M

Light Distribution Curve

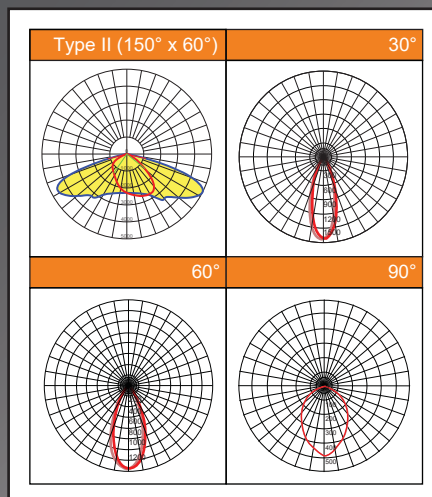

*Optional for GPRS/Zigbee/LoRaWAN Smart System

* Size and weight may have a tolerance of +-10%

JKC-L-60W Integrated Solar LED Floodlight/ Street Light

(Type A: 3 days autonomy / Type B: 2 days autonomy)



Casing Material

Aluminium Alloy

Dimming System

12H 100%

Wire Connector

IP68 Waterproof Connector

Packing & Weight

Product Size : 1650*680*125MM (Luminaire)
 (Type A & Type B) : 601.5*540*85.3MM (Bracket)
 Packing Size : 1730*760*225MM (Luminaire)
 (Type A & Type B) : 1000*650*180MM (Bracket)

Net Weight

Luminaire : 48KG (Type A) / 45KG (Type B)
 Bracket : 5KG (Type A & Type B)

Gross Weight

Luminaire : 50.5KG (Type A) / 47.5KG (Type B)
 Bracket : 5.7KG (Type A & Type B)

Mounting Bracket Type

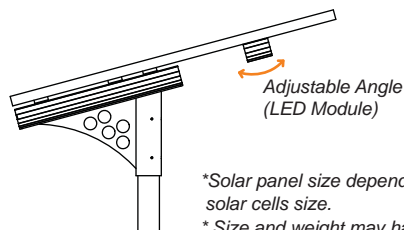

*Solar panel size depends on available solar cells size.

* Size and weight may have a tolerance of +-10%

Solar Panel

Type : Imported High Efficiency Monocrystalline Silicon
 Max Power : 36V 210W (Type A & Type B)
 Lifetime : 25 Years

Battery

Type : LiFePO4 Battery
 Rating : 25.6V 90AH (Type A)
 25.6V 60AH (Type B)
 Lifetime : 5 Years

LED Lamp

Max Power : 60W
 LED Chip : Lumileds 5050
 Chip Quantity : 28 PCS
 System Efficacy : Typical 175.15 lm/W
 Total Lumen : Typical 10,505 lm
 Lifetime : 100,000 Hours

Ingress Protection

IP66 Optical Compartment

Charge Time

By Sun : 4.5 Hours

Discharge Time

3 Cloud / Rainy Days / 36 hours (Type A)
 2 Cloud / Rainy Days / 24 hours (Type B)

Working Temperature

Range : -25°C ~ +65°C

Colour Temperature

Range : 3000K - 6500K

Mounting Recommendation

Height : 7 - 8M
 Distance : 23 - 34M

Light Distribution Curve

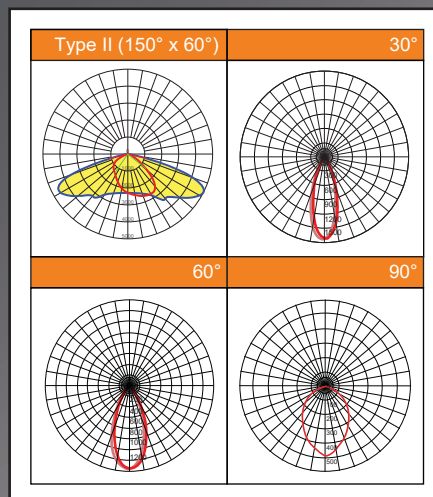

*Optional for GPRS/Zigbee/L0RaWAN Smart System

* Size and weight may have a tolerance of +-10%

JKC-L-80W Integrated Solar LED Floodlight/ Street Light

(Type A: 3 days autonomy / Type B: 2 days autonomy)



Casing Material

Aluminium Alloy

Dimming System

12H 100%

Wire Connector

IP68 Waterproof Connector

Packing & Weight

Product Size : 1650*680*125MM (Luminaire)
 (Type A & Type B) : 601.5*540*85.3MM (Bracket)
 Packing Size : 1730*760*225MM (Luminaire)
 (Type A & Type B) : 1000*650*180MM (Bracket)

Net Weight

Luminaire : 63KG (Type A) / 58KG (Type B)
 Bracket : 5KG (Type A & Type B)

Gross Weight

Luminaire : 65.5KG (Type A) / 60.5KG (Type B)
 Bracket : 5.7KG (Type A & Type B)

Mounting Bracket Type

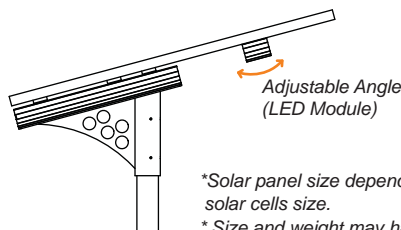

Solar Panel

Type : Imported High Efficiency Monocrystalline Silicon
 Max Power : 36V 210W (Type A & Type B)
 Lifetime : 25 Years

Battery

Type : LiFePO4 Battery
 Rating : 25.6V 150AH (Type A)
 25.6V 90AH (Type B)
 Lifetime : 5 Years

LED Lamp

Max Power : 80W
 LED Chip : Lumileds 5050
 Chip Quantity : 48 PCS
 System Efficacy : Typical 185.62 lm/W
 Total Lumen : Typical 14,850 lm
 Lifetime : 100,000 Hours

Ingress Protection

IP66 Optical Compartment

Charge Time

By Sun : 4.5 Hours

Discharge Time

3 Cloud / Rainy Days / 36 hours (Type A)
 2 Cloud / Rainy Days / 24 hours (Type B)

Working Temperature

Range : -25°C ~ +65°C

Colour Temperature

Range : 3000K - 6500K

Mounting Recommendation

Height : 8 - 10M
 Distance : 23 - 34M

Light Distribution Curve

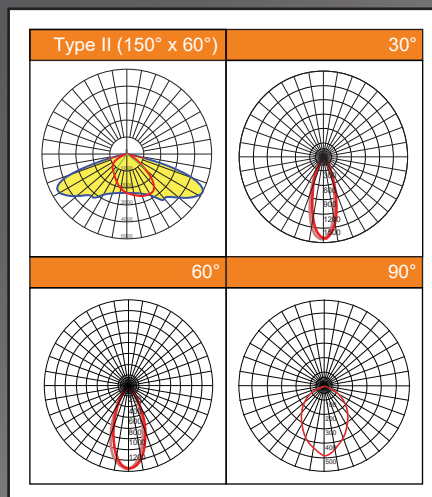

*Optional for GPRS/Zigbee/L0RaWAN Smart System

* Size and weight may have a tolerance of +-10%

JKC-L-100W Integrated Solar LED Floodlight/ Street Light

(Type A: 3 days autonomy / Type B: 2 days autonomy)



Solar Panel

Type : Imported High Efficiency Monocrystalline Silicon
 Max Power : 36V 320W (Type A & Type B)
 Lifetime : 25 Years

Battery

Type : LiFePO4 Battery
 Rating : 25.6V 180AH (Type A)
 25.6V 120AH (Type B)
 Lifetime : 5 Years

LED Lamp

Max Power : 100W
 LED Chip : Lumileds 5050
 Chip Quantity : 48 PCS
 System Efficacy : Typical 146.76 lm/W
 Total Lumen : Typical 14,735 lm
 Lifetime : 100,000 Hours

Ingress Protection

IP66 Optical Compartment

Charge Time

By Sun : 4.5 Hours

Discharge Time

3 Cloud / Rainy Days / 36 hours (Type A)
 2 Cloud / Rainy Days / 24 hours (Type B)

Working Temperature

Range : -25°C ~ +65°C

Colour Temperature

Range : 3000K - 6500K

Mounting Recommendation

Height : 9 - 12M
 Distance : 23 - 34M

Casing Material

Aluminium Alloy

Dimming System

12H 100%

Wire Connector

IP68 Waterproof Connector

Packing & Weight

Product Size : 1650*1250*125MM (Luminaire)
 (Type A & Type B) : 601.5*540*85.3MM (Bracket)
 Packing Size : 1730*1330*225MM (Luminaire)
 (Type A & Type B) : 1000*650*180MM (Bracket)

Net Weight

Luminaire : 68KG (Type A) / 63KG (Type B)
 Bracket : 8.5KG (Type A & Type B)
 Gross Weight
 Luminaire : 70.5KG (Type A) / 65.5KG (Type B)
 Bracket : 9.2KG (Type A & Type B)

Mounting Bracket Type

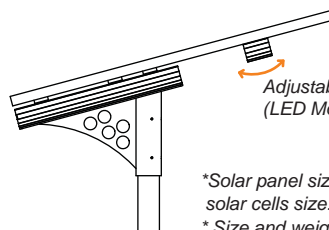

*Solar panel size depends on available solar cells size.
 * Size and weight may have a tolerance of +-10%

Light Distribution Curve

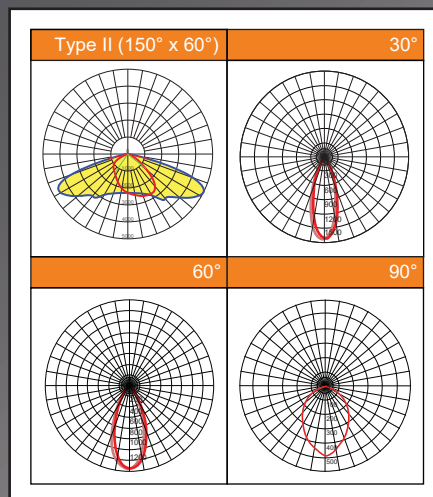

*Optional for GPRS/Zigbee/L0RaWAN Smart System

* Size and weight may have a tolerance of +-10%

JKC-L-120W Integrated Solar LED Floodlight/ Street Light

(Type A: 3 days autonomy / Type B: 2 days autonomy)



Casing Material

Aluminium Alloy

Dimming System

12H 100%

Wire Connector

IP68 Waterproof Connector

Packing & Weight

Product Size : 1650*1250*125MM (Luminaire)
 (Type A & Type B) : 601.5*540*85.3MM (Bracket)
 Packing Size : 1730*1330*225MM (Luminaire)
 (Type A & Type B) : 1000*650*180MM (Bracket)

Net Weight

Luminaire : 78KG (Type A) / 75KG (Type B)
 Bracket : 8.5KG (Type A & Type B)
 Gross Weight
 Luminaire : 80.5KG (Type A) / 77.5KG (Type B)
 Bracket : 9.2KG (Type A & Type B)

Mounting Bracket Type

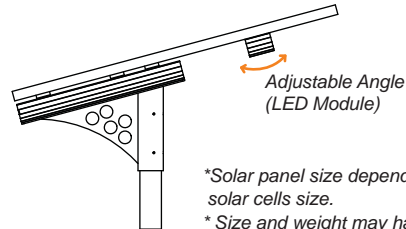

Solar Panel

Type : Imported High Efficiency Monocrystalline Silicon
 Max Power : 36V 320W (Type A & Type B)
 Lifetime : 25 Years

Battery

Type : LiFePO4 Battery
 Rating : 25.6V 210AH (Type A)
 25.6V 150AH (Type B)
 Lifetime : 5 Years

LED Lamp

Max Power : 120W
 LED Chip : Lumileds 5050
 Chip Quantity : 48 PCS
 System Efficacy : Typical 138.9 lm/W
 Total Lumen : Typical 16,751 lm
 Lifetime : 100,000 Hours

Ingress Protection

IP66 Optical Compartment

Charge Time

By Sun : 4.5 Hours

Discharge Time

3 Cloud / Rainy Days / 36 hours (Type A)
 2 Cloud / Rainy Days / 24 hours (Type B)

Working Temperature

Range : -30°C ~ +70°C

Colour Temperature

Range : 3000K - 6500K

Mounting Recommendation

Height : 9 - 12M
 Distance : 30 - 38M

Light Distribution Curve

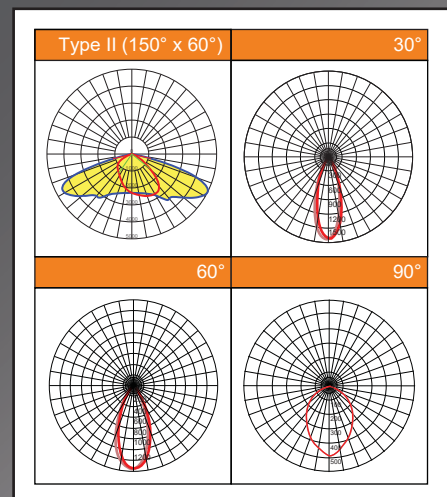

*Optional for GPRS/Zigbee/L0RaWAN Smart System

* Size and weight may have a tolerance of +-10%

JKC-L-150W Integrated Solar LED Floodlight/ Street Light

(Type A: 3 days autonomy / Type B: 2 days autonomy)



Solar Panel

Type : Imported High Efficiency Monocrystalline Silicon
 Max Power : 36V 400W (Type A & Type B)
 Lifetime : 25 Years

Battery

Type : LiFePO4 Battery
 Rating : 25.6V 270AH (Type A)
 25.6V 180AH (Type B)
 Lifetime : 5 Years

LED Lamp

Max Power : 150W
 LED Chip : Lumileds 5050
 Chip Quantity : 48 PCS
 System Efficacy : Typical 132.54 lm/W
 Total Lumen : Typical 19,947 lm
 Lifetime : 100,000 Hours

Ingress Protection

IP66 Optical Compartment

Charge Time

By Sun : 4.5 Hours

Discharge Time

3 Cloud / Rainy Days / 36 hours (Type A)
 2 Cloud / Rainy Days / 24 hours (Type B)

Working Temperature

Range : -30°C ~ +70°C

Colour Temperature

Range : 3000K - 6500K

Mounting Recommendation

Height : 9 - 12M
 Distance : 35 - 40M

Casing Material

Aluminium Alloy

Dimming System

12H 100%

Wire Connector

IP68 Waterproof Connector

Packing & Weight

Product Size : 1650*1350*125MM (Luminaire)
 (Type A & Type B) : 601.5*540*85.3MM (Bracket)
 Packing Size : 1730*1430*225MM (Luminaire)
 (Type A & Type B) : 1000*650*180MM (Bracket)

Net Weight

Luminaire : 88KG (Type A) / 85KG (Type B)
 Bracket : 8.5KG (Type A & Type B)
 Gross Weight
 Luminaire : 90.5KG (Type A) / 87.5KG (Type B)
 Bracket : 9.2KG (Type A & Type B)

Mounting Bracket Type

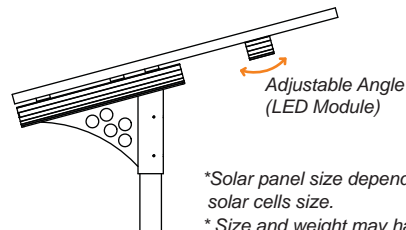

Light Distribution Curve

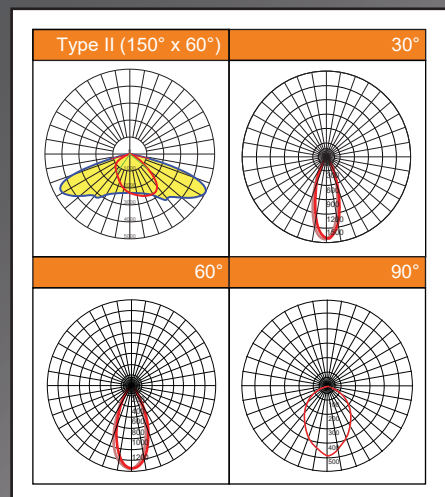

*Optional for GPRS/Zigbee/L0RaWAN Smart System

* Size and weight may have a tolerance of +-10%

JKC-KM-20W Integrated Solar LED Street Light

(Type A: 3 days autonomy / Type B: 2 days autonomy)



Mounting Recommendation

Height : 6 - 7M
Distance : 19 - 22M

Casing Material

Aluminium Alloy

Dimming System

15% Brightness on Standby,
100% Brightness on Induction,
Idle for 60 seconds, back to Standby Mode

Packing & Weight

Product Size : 785*410*60MM (Luminaire)
: 365*170*190MM (Bracket)
Packing Size : 865*490*160MM (Luminaire)
: 845*115*470MM (Bracket)
Net Weight : 7.6KG (Luminaire)
: 2.1KG (Bracket 1)
: 1.7KG (Bracket 2)
Gross Weight : 10.1KG (Luminaire)
: 2.8KG (Bracket 1)
: 2.4KG (Bracket 2)

Mounting Bracket Type

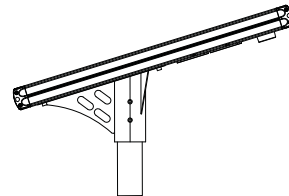

Solar Panel

Type : Imported High Efficiency
Monocrystalline Silicon
Max Power : 18V 50W
Lifetime : 25 Years

Battery

Type : LiFePO4 Battery
Rating : 12.8V 15AH
Lifetime : 5 Years

LED Lamp

Max Power : 20W
LED Chip : Bridgelux
Chip Quantity : 56 PCS
System Efficacy : 170 lm/W
Total Lumen : 3,400 lm
Lifetime : 100,000 Hours
Light Distribution Type : 140°

Ingress Protection

IP Protection : IP65

Charge Time

By Sun : 6 Hours

Discharge Time

3 - 5 Cloud/ Rainy Days

Working Temperature

Range : -30°C ~ +70°C

Colour Temperature

Range : 2700K - 6500K

Light Distribution Curve

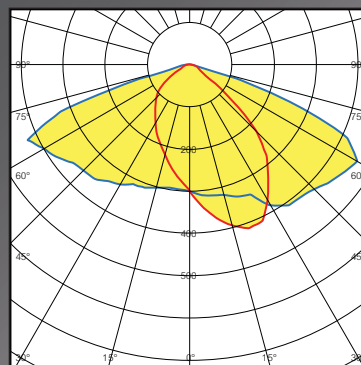

*Optional for GPRS/Zigbee/LoRaWAN Smart System

JKC-KM-40W Integrated Solar LED Street Light

(Type A: 3 days autonomy / Type B: 2 days autonomy)



Mounting Recommendation

Height : 6 - 7M
Distance : 19 - 22M

Casing Material

Aluminium Alloy

Dimming System

15% Brightness on Standby,
100% Brightness on Induction,
Idle for 60 seconds, back to Stand by Mode

Packing & Weight

Product Size : 785*410*60MM (Luminaire)
: 365*170*190MM (Bracket)
Packing Size : 865*490*160MM (Luminaire)
: 380*180*200MM (Bracket)
Net Weight : 7.6KG (Luminaire)
: 2.1KG (Bracket 1)
: 1.7KG (Bracket 2)
Gross Weight : 10.1KG (Luminaire)
: 2.8KG (Bracket 1)
: 2.4KG (Bracket 2)

Mounting Bracket Type

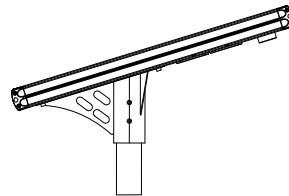

Light Distribution Curve

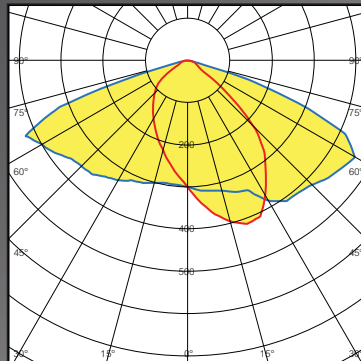

*Optional for GPRS/Zigbee/LoRaWAN Smart System

Solar Panel

Type : Imported High Efficiency
Monocrystalline Silicon
Max Power : 18V 50W
Lifetime : 25 Years

Battery

Type : LiFePO4 Battery
Rating : 12.8V 15AH
Lifetime : 5 Years

LED Lamp

Max Power : 40W
LED Chip : Bridgelux
Chip Quantity : 56 PCS
System Efficacy : 170 lm/W
Total Lumen : 6,800 lm
Lifetime : 100,000 Hours
Light Distribution Type : 140°

Ingress Protection

IP Protection : IP65

Charge Time

By Sun : 6 Hours

Discharge Time

3 - 5 Cloud/ Rainy Days

Working Temperature

Range : -30°C ~ +70°C

Colour Temperature

Range : 2700K - 6500K

JKC-KM-60W Integrated Solar LED Street Light

(Type A: 3 days autonomy / Type B: 2 days autonomy)



Mounting Recommendation

Height : 7 - 8M
Distance : 22 - 26M

Casing Material

Aluminium Alloy

Dimming System

15% Brightness on Standby,
100% Brightness on Induction,
Idle for 60 seconds, back to Standby Mode

Packing & Weight

Product Size : 1220*410*60MM (Luminaire)
: 365*170*190MM (Bracket)
Packing Size : 1300*490*160MM (Luminaire)
: 380*180*200MM (Bracket)
Net Weight : 11.6KG (Luminaire)
: 2.1KG (Bracket 1)
: 1.7KG (Bracket 2)
Gross Weight : 14.1KG (Luminaire)
: 2.8KG (Bracket 1)
: 2.4KG (Bracket 2)

Mounting Bracket Type

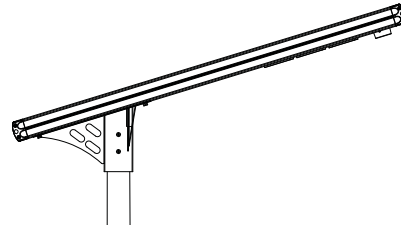

Light Distribution Curve

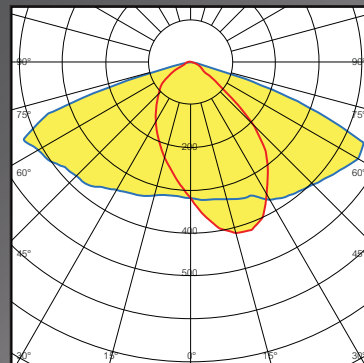

*Optional for GPRS/Zigbee/LoRaWAN Smart System

Solar Panel

Type : Imported High Efficiency Monocrystalline Silicon
Max Power : 18V 90W
Lifetime : 25 Years

Battery

Type : LiFePO4 Battery
Rating : 12.8V 30AH
Lifetime : 5 Years

LED Lamp

Max Power : 60W
LED Chip : Bridgelux
Chip Quantity : 84 PCS
System Efficacy : 170 lm/W
Total Lumen : 10,200 lm
Lifetime : 100,000 Hours
Light Distribution Type : 140°

Ingress Protection

IP Protection : IP65

Charge Time

By Sun : 6 Hours

Discharge Time

3 - 5 Cloud/ Rainy Days

Working Temperature

Range : -30°C ~ +70°C

Colour Temperature

Range : 2700K - 6500K

JKC-KM-80W Integrated Solar LED Street Light

(Type A: 3 days autonomy / Type B: 2 days autonomy)



Mounting Recommendation

Height : 8 - 9M
Distance : 26 - 29M

Casing Material

Aluminium Alloy

Dimming System

15% Brightness on Standby,
100% Brightness on Induction,
Idle for 60 seconds, back to Standby Mode

Packing & Weight

Product Size : 1220*410*60MM (Luminaire)
: 365*170*190MM (Bracket)
Packing Size : 1300*490*160MM (Luminaire)
: 380*180*200MM (Bracket)
Net Weight : 12.8KG (Luminaire)
: 2.1KG (Bracket 1)
: 1.7KG (Bracket 2)
Gross Weight : 15.3KG (Luminaire)
: 2.8KG (Bracket 1)
: 2.4KG (Bracket 2)

Mounting Bracket Type

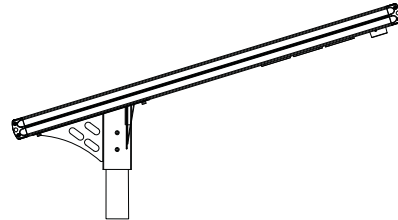

Solar Panel

Type : Imported High Efficiency Monocrystalline Silicon
Max Power : 18V 90W
Lifetime : 25 Years

Battery

Type : LiFePO4 Battery
Rating : 12.8V 45AH
Lifetime : 5 Years

LED Lamp

Max Power : 80W
LED Chip : Bridgelux
Chip Quantity : 84 PCS
System Efficacy : 170 lm/W
Total Lumen : 13,600 lm
Lifetime : 100,000 Hours
Light Distribution Type : 140°

Ingress Protection

IP Protection : IP65

Charge Time

By Sun : 6 Hours

Discharge Time

3 - 5 Cloud/ Rainy Days

Working Temperature

Range : -30°C ~ +70°C

Colour Temperature

Range : 2700K - 6500K

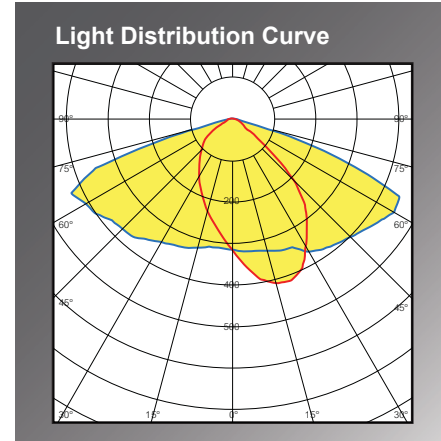

*Optional for GPRS/Zigbee/LoRaWAN Smart System

JKC-KM-100W Integrated Solar LED Street Light

(Type A: 3 days autonomy / Type B: 2 days autonomy)



Solar Panel

Type	: Imported High Efficiency Monocrystalline Silicon
Max Power	: 18V 120W
Lifetime	: 25 Years

Battery

Type	: LiFePO4 Battery
Rating	: 12.8V 45AH
Lifetime	: 5 Years

LED Lamp

Max Power	: 100W
LED Chip	: Bridgelux
Chip Quantity	: 112 PCS
System Efficacy	: 170 lm/W
Total Lumen	: 17,000 lm
Lifetime	: 100,000 Hours
Light Distribution Type	: 140°

Ingress Protection

IP Protection	: IP65
---------------	--------

Charge Time

By Sun	: 6 Hours
--------	-----------

Discharge Time

3 - 5 Cloud/ Rainy Days

Working Temperature

Range	: -30°C ~ +65°C
-------	-----------------

Colour Temperature

Range	: 2700K - 6500K
-------	-----------------

Mounting Recommendation

Height	: 8 - 9M
Distance	: 26 - 29M

Casing Material

Aluminium Alloy

Dimming System

15% Brightness on Standby,
100% Brightness on Induction,
Idle for 60 seconds, back to Standby Mode

Packing & Weight

Product Size	: 1675*410*60MM (Luminaire)
	: 640*165*240MM (Bracket)
Packing Size	: 1755*490*160MM (Luminaire)
	: 650*235*290MM (Bracket)
Net Weight	: 16.2KG (Luminaire)
	: 6.1KG (Bracket 1)
Gross Weight	: 5.7KG (Bracket 2)
	: 18.7KG (Luminaire)
	: 6.8KG (Bracket 1)
	: 6.4KG (Bracket 2)

Mounting Bracket Type

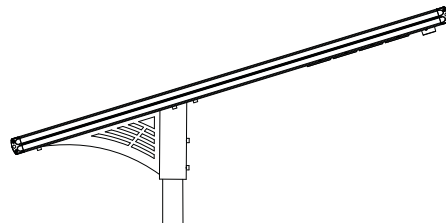

Light Distribution Curve

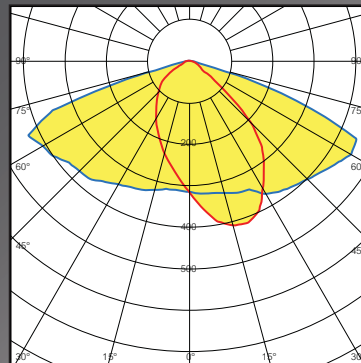

*Optional for GPRS/Zigbee/LoRaWAN Smart System

JKC-KM-120W Integrated Solar LED Street Light

(Type A: 3 days autonomy / Type B: 2 days autonomy)



Solar Panel

Type : Imported High Efficiency Monocrystalline Silicon
 Max Power : 18V 160W (Type A & Type B)
 Lifetime : 25 Years

Battery

Type : LiFePO4 Battery
 Rating : 12.8V 60AH
 Lifetime : 5 Years

LED Lamp

Max Power : 120W
 LED Chip : Bridgelux
 Chip Quantity : 112 PCS
 System Efficacy : 170 lm/W
 Total Lumen : 20,400 lm
 Lifetime : 100,000 Hours
 Light Distribution Type : 140°

Ingress Protection

IP Protection : IP65

Charge Time

By Sun : 6 Hours

Discharge Time

3 - 5 Cloud/ Rainy Days

Working Temperature

Range : -30°C ~ +70°C

Colour Temperature

Range : 2700K - 6500K

Mounting Recommendation

Height : 9 - 10M
 Distance : 29 - 32M

Casing Material

Aluminium Alloy

Dimming System

15% Brightness on Standby,
 100% Brightness on Induction,
 Idle for 60 seconds, back to Standby Mode

Packing & Weight

Product Size : 1445*600*60MM (Luminaire)
 : 640*225*290MM (Bracket)
 Packing Size : 1525*680*160MM (Luminaire)
 : 650*235*300MM (Bracket)
 Net Weight : 19.6KG (Luminaire)
 : 3.9KG (Bracket 1)
 : 3.5KG (Bracket 2)
 Gross Weight : 22.1KG (Luminaire)
 : 4.6KG (Bracket 1)
 : 4.2KG (Bracket 2)

Mounting Bracket Type

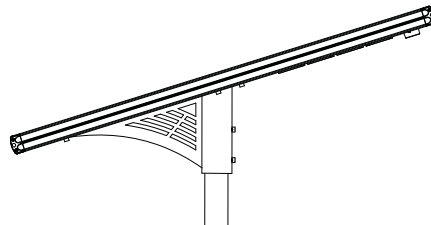

Light Distribution Curve

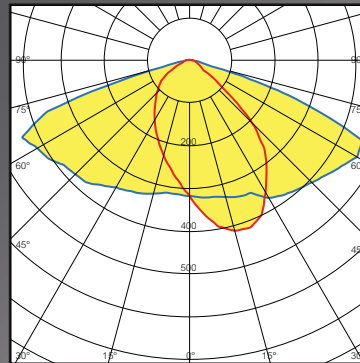

*Optional for GPRS/Zigbee/LoRaWAN Smart System

JKC-KM-150W Integrated Solar LED Street Light

(Type A: 3 days autonomy / Type B: 2 days autonomy)



Mounting Recommendation

Height : 9 - 10M
Distance : 29 - 32M

Casing Material

Aluminium Alloy

Dimming System

15% Brightness on Standby,
100% Brightness on Induction,
Idle for 60 seconds, back to Standby Mode

Packing & Weight

Product Size : 1615*600*60MM (Luminaire)
: 640*225*290MM (Bracket)
Packing Size : 1695*680*160MM (Luminaire)
: 650*235*300MM (Bracket)
Net Weight : 22KG (Luminaire)
: 6.1KG (Bracket 1)
: 5.7KG (Bracket 2)
Gross Weight : 24.5KG (Luminaire)
: 6.8KG (Bracket 1)
: 6.4KG (Bracket 2)

Mounting Bracket Type

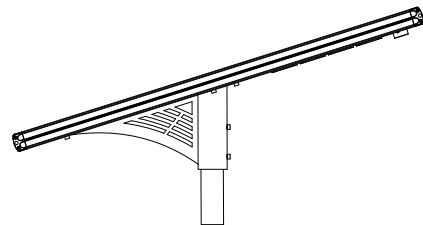

Light Distribution Curve

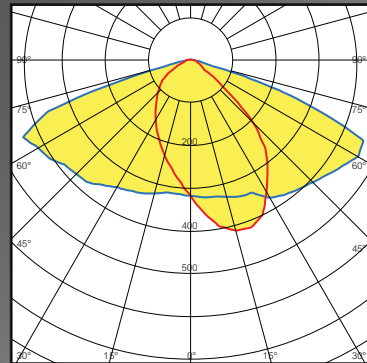

*Optional for GPRS/Zigbee/LoRaWAN Smart System

Solar Panel

Type : Imported High Efficiency Monocrystalline Silicon
Max Power : 18V 180W
Lifetime : 25 Years

Battery

Type : LiFePO4 Battery
Rating : 12.8V 75AH
Lifetime : 5 Years

LED Lamp

Max Power : 150W
LED Chip : Bridgelux
Chip Quantity : 140 PCS
System Efficacy : 170 lm/W
Total Lumen : 25,500 lm
Lifetime : 100,000 Hours
Light Distribution Type : 140°

Ingress Protection

IP Protection : IP65

Charge Time

By Sun : 6 Hours

Discharge Time

3 - 5 Cloud/ Rainy Days

Working Temperature

Range : -30°C ~ +70°C

Colour Temperature

Range : 2700K - 6500K

JKC-FX-40W Integrated Solar LED Street Light

(Type A: 3 days autonomy / Type B: 2 days autonomy)



Solar Panel

Type	: Imported High Efficiency Monocrystalline Silicon
Max Power	: 18V 65W
Lifetime	: 25 Years

Battery

Type	: LiFePO4 Battery
Rating	: 12.8V 15AH
Lifetime	: 5 Years

LED Lamp

Max Power	: 40W
LED Chip	: Bridgelux 3030
Chip Quantity	: 96 PCS
System Efficacy	: 170 lm/W
Total Lumen	: 6,800 lm
Lifetime	: 100,000 Hours
Light Distribution Type	: 140° x 70°

Ingress Protection

IP65 Optical Compartment

Charge Time

By Sun	: 8 Hours
--------	-----------

Discharge Time

Full Power	: > 15 hours
Half Power	: > 30 hours

Working Temperature

Range	: -25°C ~ +65°C
-------	-----------------

Colour Temperature

Range	: 2700K - 6500K
-------	-----------------

Mounting Recommendation

Height	: 4 - 7M
Distance	: 13 - 23M

Casing Material

Aluminium Alloy

Motion Sensor Setting

Night Sensor + Microwave Motion Sensor

Wire Connector

IP68 Waterproof Connector

Packing & Weight

Product Size	: 848*385*108MM (Luminaire)
	: 560*310*125MM (Bracket Axle)
Packing Size	: 910*450*90MM (Luminaire)
	: 620*370*140MM (Bracket Axle)
Net Weight	: 6.6KG (Luminaire)
	: 5.4KG (Bracket Axle)
Gross Weight	: 9.1KG (Luminaire)
	: 6.1KG (Bracket Axle)

Mounting Bracket Type

Vertical

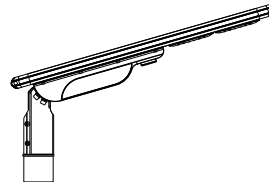

Horizontal



Light Distribution Curve

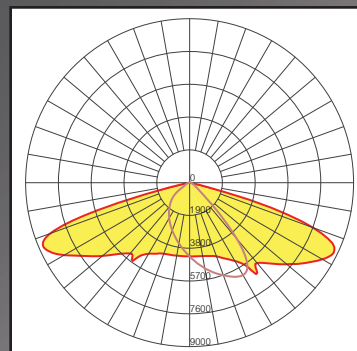

*Optional for GPRS/Zigbee/L0RaWAN Smart System

* Size and weight may have a tolerance of +/-10%

JKC-FX-50W Integrated Solar LED Street Light

(Type A: 3 days autonomy / Type B: 2 days autonomy)



Solar Panel

Type : Imported High Efficiency Monocrystalline Silicon
 Max Power : 18V 70W
 Lifetime : 25 Years

Battery

Type : LiFePO4 Battery
 Rating : 12.8V 30AH
 Lifetime : 5 Years

LED Lamp

Max Power : 50W
 LED Chip : Bridgelux 3030
 Chip Quantity : 144 PCS
 System Efficacy : 170 lm/W
 Total Lumen : 8,500 lm
 Lifetime : 100,000 Hours
 Light Distribution Type : 140° x 70°

Ingress Protection

IP65 Optical Compartment

Charge Time

By Sun : 8 Hours

Discharge Time

Full Power : > 15 hours
 Half Power : > 30 hours

Working Temperature

Range : -25°C ~ +65°C

Colour Temperature

Range : 2700K - 6500K

Mounting Recommendation

Height : 5 - 7M
 Distance : 21 - 24M

Casing Material

Aluminium Alloy

Motion Sensor Setting

Night Sensor + Microwave Motion Sensor

Wire Connector

IP68 Waterproof Connector

Packing & Weight

Product Size : 1077*385*108MM (Luminaire)
 : 560*310*125MM (Bracket Axle)
 Packing Size : 1140*450*90MM (Luminaire)
 : 620*370*140MM (Bracket Axle)
 Net Weight : 8.5KG (Luminaire)
 : 6.5KG (Bracket Axle)
 Gross Weight : 11KG (Luminaire)
 : 7.2KG (Bracket Axle)

Mounting Bracket Type

Vertical

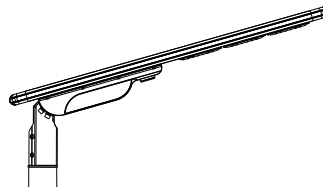

Horizontal



Light Distribution Curve

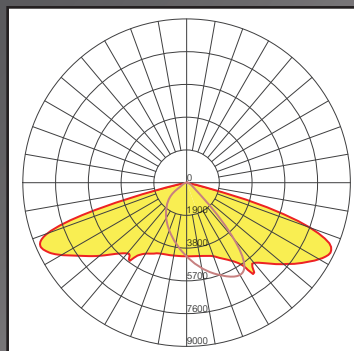

*Optional for GPRS/Zigbee/LoRaWAN Smart System

* Size and weight may have a tolerance of +/-10%

JKC-FX-60W Integrated Solar LED Street Light

(Type A: 3 days autonomy / Type B: 2 days autonomy)



Mounting Recommendation

Height : 5 - 8M
Distance : 17 - 27M

Casing Material

Aluminium Alloy

Motion Sensor Setting

Night Sensor + Microwave Motion Sensor

Wire Connector

IP68 Waterproof Connector

Packing & Weight

Product Size : 1077*385*108MM (Luminaire)
: 560*310*125MM (Bracket Axle)
Packing Size : 1140*450*90MM (Luminaire)
: 620*370*140MM (Bracket Axle)
Net Weight : 8.5KG (Luminaire)
: 6.5KG (Bracket Axle)
Gross Weight : 11KG (Luminaire)
: 7.2KG (Bracket Axle)

Mounting Bracket Type

Vertical

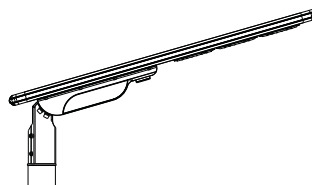

Horizontal



Light Distribution Curve

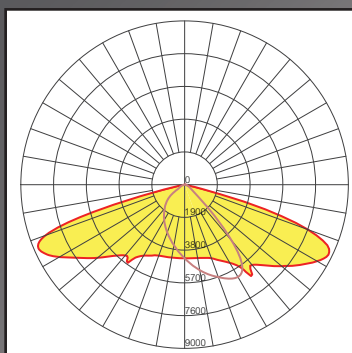

*Optional for GPRS/Zigbee/LoRaWAN Smart System

Solar Panel

Type : Imported High Efficiency Monocrystalline Silicon
Max Power : 18V 70W
Lifetime : 25 Years

Battery

Type : LiFePO4 Battery
Rating : 12.8V 30AH
Lifetime : 5 Years

LED Lamp

Max Power : 60W
LED Chip : Bridgelux 3030
Chip Quantity : 144 PCS
System Efficacy : 170 lm/W
Total Lumen : 10,200 lm
Lifetime : 100,000 Hours
Light Distribution Type : 140° x 70°

Ingress Protection

IP65 Optical Compartment

Charge Time

By Sun : 8 Hours

Discharge Time

Full Power : > 15 hours
Half Power : > 30 hours

Working Temperature

Range : -25°C ~ +65°C

Colour Temperature

Range : 2700K - 6500K

* Size and weight may have a tolerance of +-10%

JKC-FX-80W Integrated Solar LED Street Light

(Type A: 3 days autonomy / Type B: 2 days autonomy)



Mounting Recommendation

Height : 6 - 9M
Distance : 20 - 30M

Casing Material

Aluminium Alloy

Motion Sensor Setting

Night Sensor + Microwave Motion Sensor

Wire Connector

IP68 Waterproof Connector

Packing & Weight

Product Size : 1548*385*108MM (Luminaire)
: 560*310*125MM (Bracket Axle)
Packing Size : 1610*450*90MM (Luminaire)
: 620*370*140MM (Bracket Axle)
Net Weight : 8.5KG (Luminaire)
: 11.5KG (Bracket Axle)
Gross Weight : 11KG (Luminaire)
: 12.2KG (Bracket Axle)

Mounting Bracket Type

Vertical

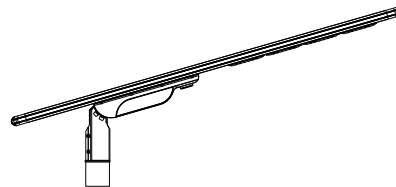

Horizontal



Solar Panel

Type : Imported High Efficiency
Monocrystalline Silicon
Max Power : 18V 100W
Lifetime : 25 Years

Battery

Type : LiFePO4 Battery
Rating : 12.8V 45AH
Lifetime : 5 Years

LED Lamp

Max Power : 80W
LED Chip : Bridgelux 3030
Chip Quantity : 192 PCS
System Efficacy : 170 lm/W
Total Lumen : 13,600 lm
Lifetime : 100,000 Hours
Light Distribution Type : 140° x 70°

Ingress Protection

IP65 Optical Compartment

Charge Time

By Sun : 8 Hours

Discharge Time

Full Power : > 15 hours
Half Power : > 30 hours

Working Temperature

Range : -25°C ~ +65°C

Colour Temperature

Range : 2700K - 6500K

Light Distribution Curve

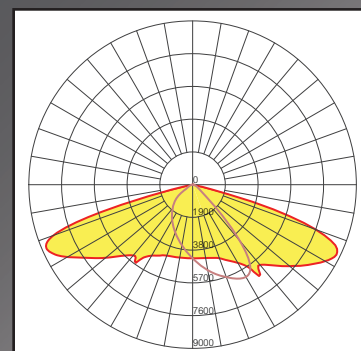

*Optional for GPRS/Zigbee/LoRaWAN Smart System

* Size and weight may have a tolerance of +/-10%

JKC-FX-100W Integrated Solar LED Street Light

(Type A: 3 days autonomy / Type B: 2 days autonomy)



Mounting Recommendation

Height : 7 - 10M
Distance : 23 - 34M

Casing Material

Aluminium Alloy

Motion Sensor Setting

Night Sensor + Microwave Motion Sensor

Wire Connector

IP68 Waterproof Connector

Packing & Weight

Product Size : 1863*385*108MM (Luminaire)
: 560*310*125MM (Bracket Axle)
Packing Size : 1930*450*90MM (Luminaire)
: 620*370*140MM (Bracket Axle)
Net Weight : 9.8KG (Luminaire)
: 12.5KG (Bracket Axle)
Gross Weight : 12.3KG (Luminaire)
: 13.2KG (Bracket Axle)

Mounting Bracket Type

Vertical



Horizontal



Solar Panel

Type : Imported High Efficiency Monocrystalline Silicon
Max Power : 18V 120W
Lifetime : 25 Years

Battery

Type : LiFePO4 Battery
Rating : 12.8V 45AH
Lifetime : 5 Years

LED Lamp

Max Power : 100W
LED Chip : Bridgelux 3030
Chip Quantity : 192 PCS
System Efficacy : 170 lm/W
Total Lumen : 17,000 lm
Lifetime : 100,000 Hours
Light Distribution Type : 140° x 70°

Ingress Protection

IP65 Optical Compartment

Charge Time

By Sun : 8 Hours

Discharge Time

Full Power : > 15 hours
Half Power : > 30 hours

Working Temperature

Range : -25°C ~ +65°C

Colour Temperature

Range : 2700K - 6500K

Light Distribution Curve

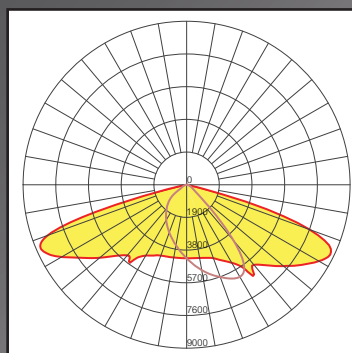

*Optional for GPRS/Zigbee/LoRaWAN Smart System

* Size and weight may have a tolerance of +/-10%

JKC-FX-120W Integrated Solar LED Street Light

(Type A: 3 days autonomy / Type B: 2 days autonomy)



Solar Panel

Type : Imported High Efficiency Monocrystalline Silicon
 Max Power : 18V 120W
 Lifetime : 25 Years

Battery

Type : LiFePO4 Battery
 Rating : 12.8V 60AH
 Lifetime : 5 Years

LED Lamp

Max Power : 120W
 LED Chip : Bridgelux 3030
 Chip Quantity : 288 PCS
 System Efficacy : 170 lm/W
 Total Lumen : 20,400 lm
 Lifetime : 100,000 Hours
 Light Distribution Type : 140° x 70°

Ingress Protection

IP65 Optical Compartment

Charge Time

By Sun : 8 Hours

Discharge Time

Full Power : > 15 hours
 Half Power : > 30 hours

Working Temperature

Range : -25°C ~ +65°C

Colour Temperature

Range : 2700K - 6500K

Mounting Recommendation

Height : 9 - 10M
 Distance : 31 - 34M

Casing Material

Aluminium Alloy

Motion Sensor Setting

Night Sensor + Microwave Motion Sensor

Wire Connector

IP68 Waterproof Connector

Packing & Weight

Product Size : 1863*385*108MM (Luminaire)
 : 560*310*125MM (Bracket Axle)
 Packing Size : 1930*450*90MM (Luminaire)
 : 620*370*140MM (Bracket Axle)
 Net Weight : 9.8KG (Luminaire)
 : 13.1KG (Bracket Axle)
 Gross Weight : 12.3KG (Luminaire)
 : 13.8KG (Bracket Axle)

Mounting Bracket Type

Vertical

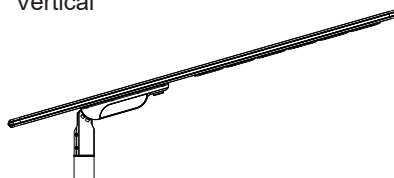

Horizontal

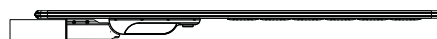

Light Distribution Curve

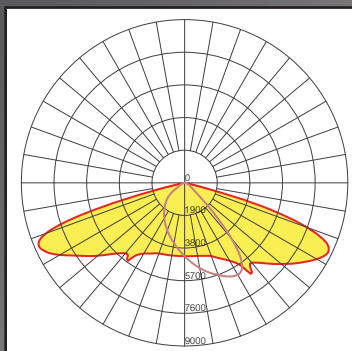

*Optional for GPRS/Zigbee/LoRaWAN Smart System

* Size and weight may have a tolerance of +/-10%

Integrated Solar Octagonal Pole/ Flange Mounted Type

POLYGONAL POLE DETAILS

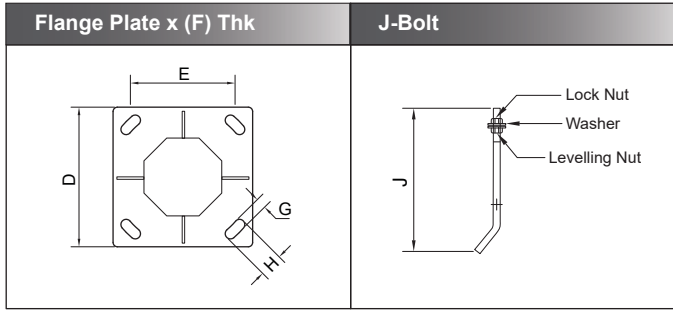

Height	Flange Plate		J-Bolt
A	D x E x (F) THK.	G x H	J
Meter	MM	MM	MM
4	195x250x9	20x45	ø16x280 (L)
6	300x220x9	25x50	ø20x450 (L)
7	300x220x9	25x50	ø20x450 (L)
8	300x220x12	25x50	ø20x450 (L)
9	300x220x12	25x50	ø20x450 (L)
10	350x260x16	30x55	ø24x570 (L)
12	400x300x16	30x55	ø24x570 (L)

*Note: Our poles are specially designed to withstand the heavy weight and extended wind inducing sail area of the solar integrated lantern. Thus, 2.5mm & 3mm thickness steel plates are utilized on our pole body with height between 7m – 12m (double arm), while the flange or anti – sinking plate varies in size and thickness depending on the pole height. Kindly request details from our team of specialist should you need it for your project.

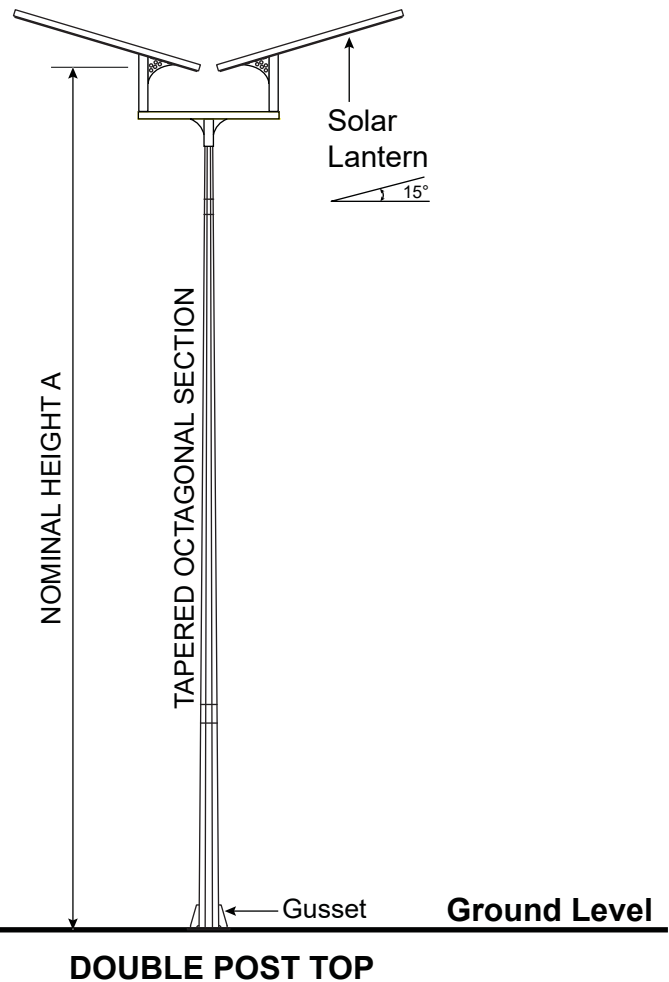
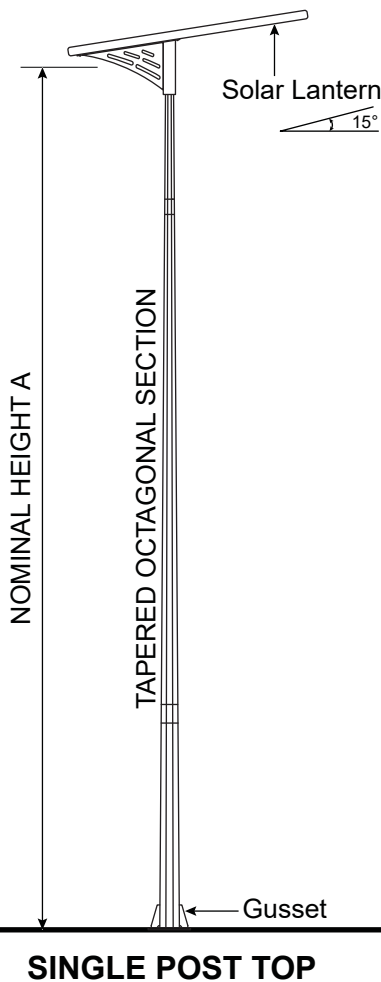

Ground Level

Integrated Solar Octagonal Pole/ Planted Type

POLYGONAL POLE DETAILS

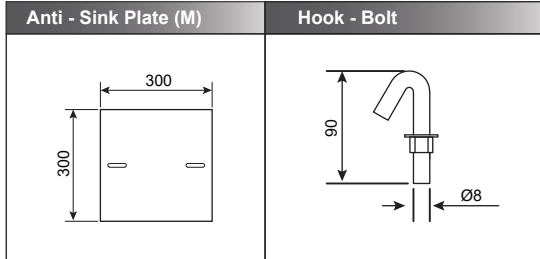

Height	Planting Depth	Anti - Sink Plate
A	L	M
Meter	MM	MM
4	400	300 x 300
6	1100	300 x 300
7	1200	300 x 300
8	1300	300 x 300
9	1400	300 x 300
10	1500	300 x 300
12	1700	300 x 300

*Note: Our poles are specially designed to withstand the heavy weight and extended wind inducing sail area of the solar integrated lantern. Thus, 2.5mm & 3mm thickness steel plates are utilized on our pole body with height between 7m – 12m (double arm), while the flange or anti – sinking plate varies in size and thickness depending on the pole height. Kindly request details from our team of specialist should you need it for your project.

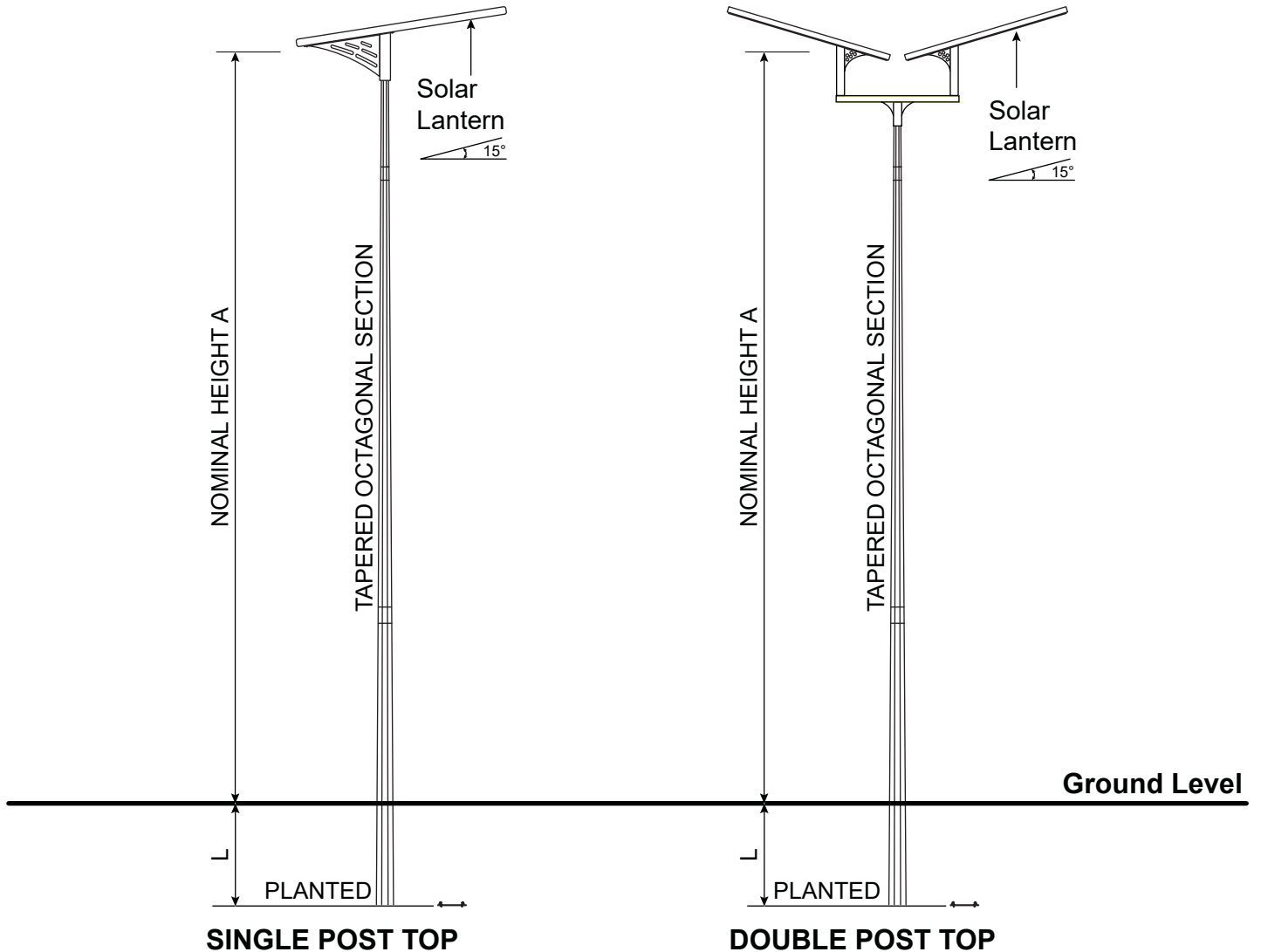

Integrated Solar Mid-Hinged/ See Saw Pole/ Flange Mounted Type

Max Top Load Weight: 20-30kg / 30-40kg / 40-60kg / 60-80kg / 80-100kg

POLYGONAL POLE DETAILS

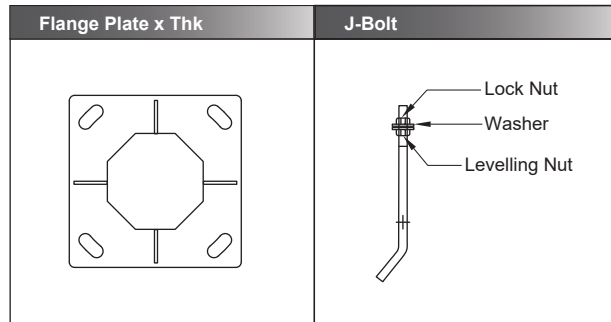

Note: Detail drawing based on request

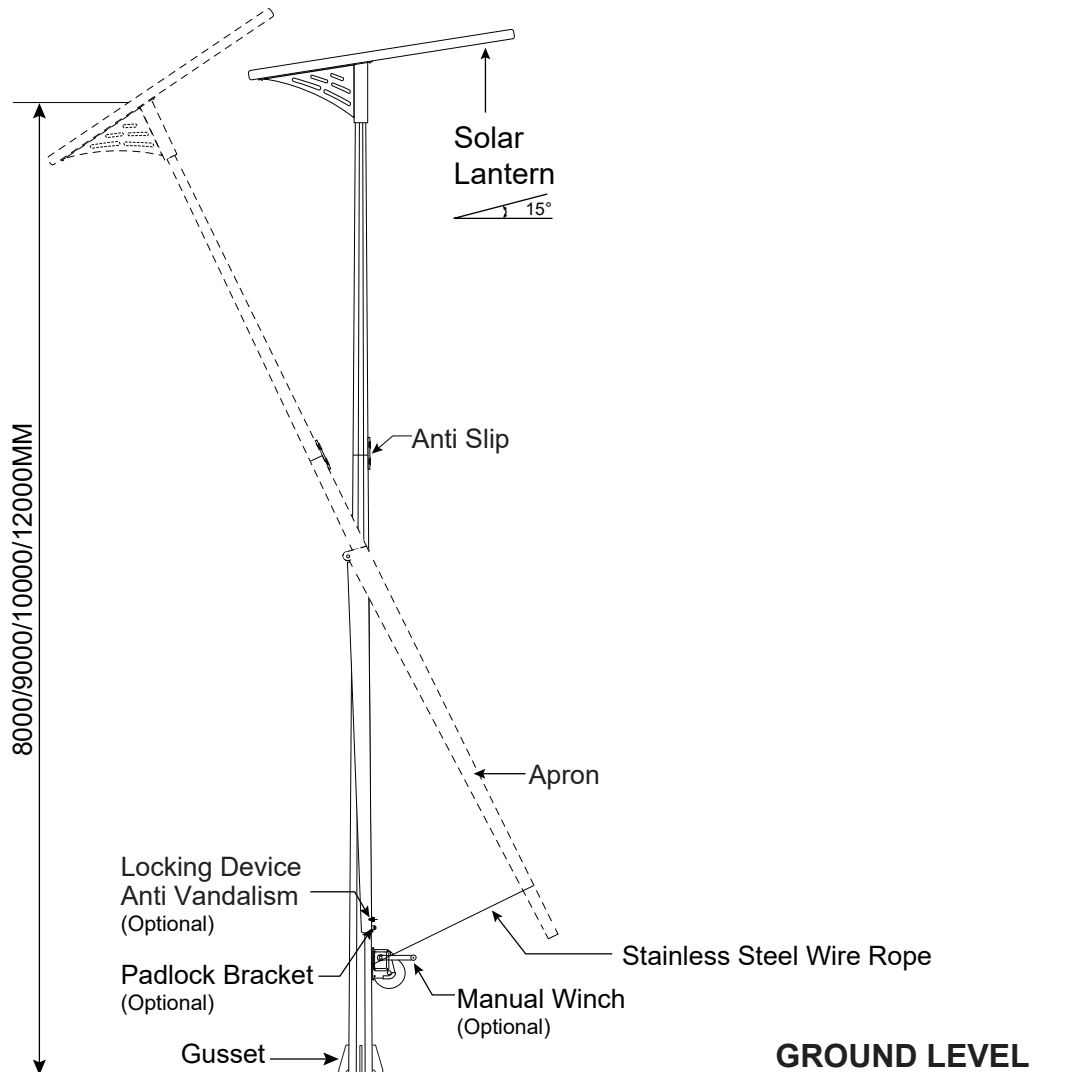

SOLAR LED STREET LIGHTING SOLUTION

LTE

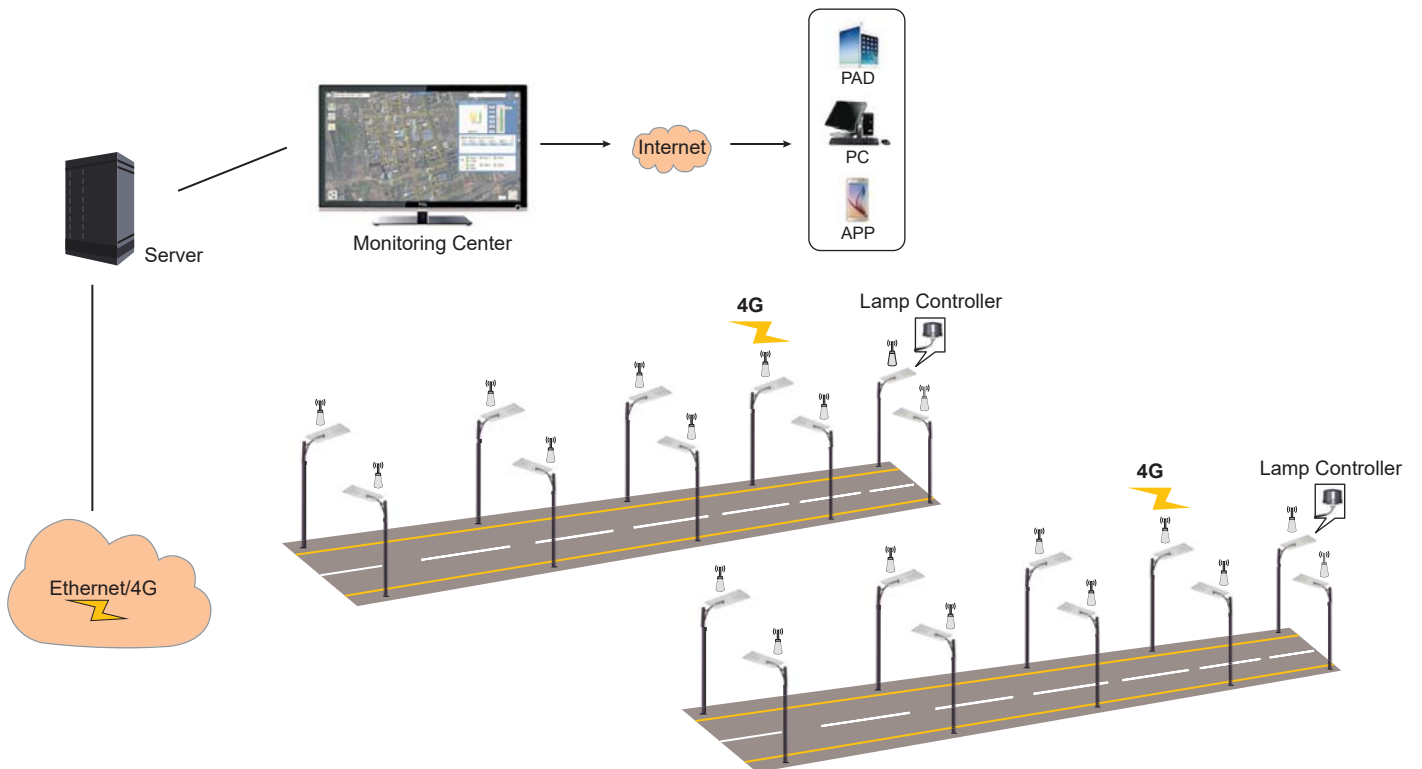
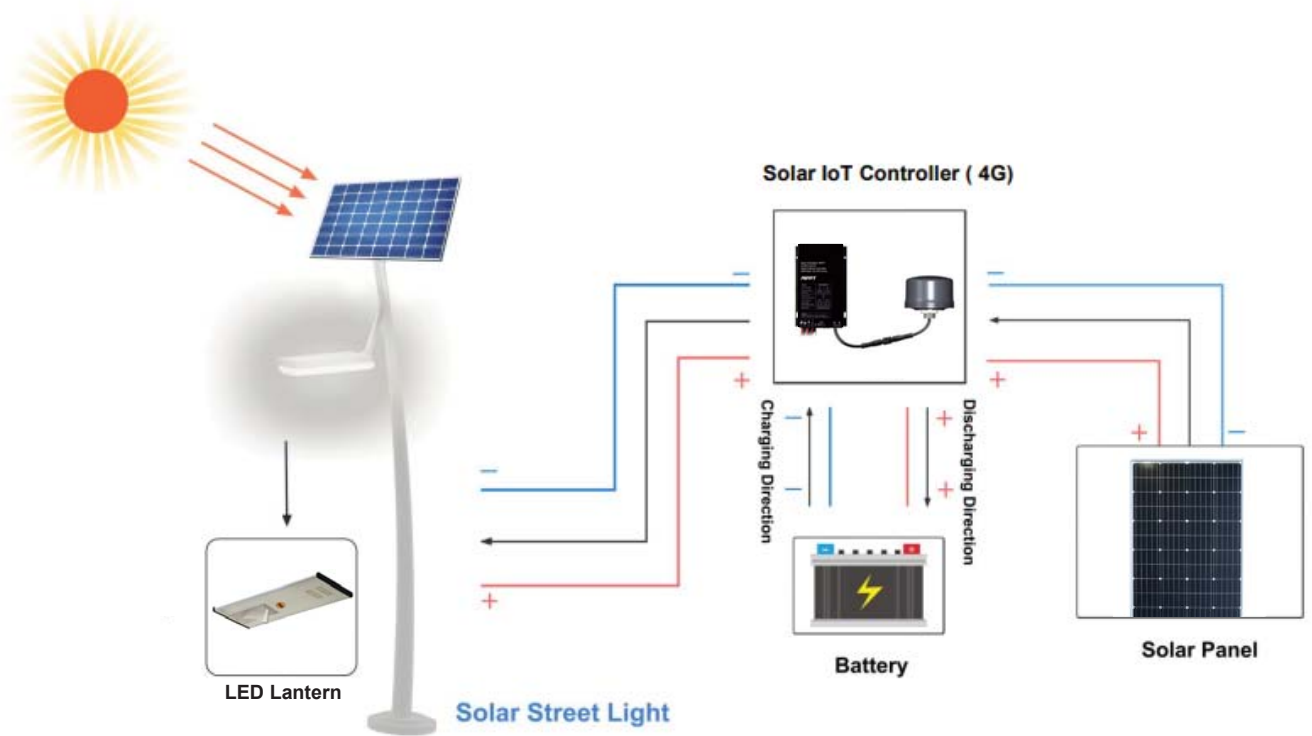

HARDWARE - SOLAR LAMP CONTROLLER

LCU71LS



LCU71LS

Basic Information

Input Parameters	Min	Typical	Max
DC Voltage 1	9V	12V	60V
DC Voltage 2 (SRNE Solar Controller)	3.9V	4V	4.2V
Average Power	1W		2W

Communication

Model	LCU71LS		
Band (Depends)	LTE FDD: B1/ 3/ 5/ 7/ 8/ 20/ 28	(Europe/ New Zealand/ Australia)	
	LTE FDD: B2/ 3/ 4/ 5/ 7/ 8/ 28/ 66	(Latin America)	
	LTE FDD: B1/ 3/ 5/ 8	LTE FDD: B34/ 38/ 39/ 40/ 41	(China/ India)
Communication Standard	LTE 3GPP Rel. 11	Transmit Power	23dBm±2.7dBm
Protocol	TCP	Receive Power	-100dBm±1dBm

External Interfaces

Communication	RS485
Quantity	1 route
Interface Protection	Internal optoelectronic isolation
Band Rate	Supports 2400/ 9600/ 115200 bps, remote configuration supported
Data Format	8 data bits, 1 stop bit, no parity/even parity, remote configuration supported

Operating Conditions

Working Temperature	-40°C ~ +85°C	Storage Temperature	-55°C ~ +125°C
IP Rating	IP66	Relative Humidity	< 95%
Weight	0.1KG	Dimensions	Φ 84mm, H 48mm

Customizations

GNSS	Customizable, support GPS/ Bei dou
------	------------------------------------

SOLAR LED STREET LIGHTING SOLUTION

LoRaMesh

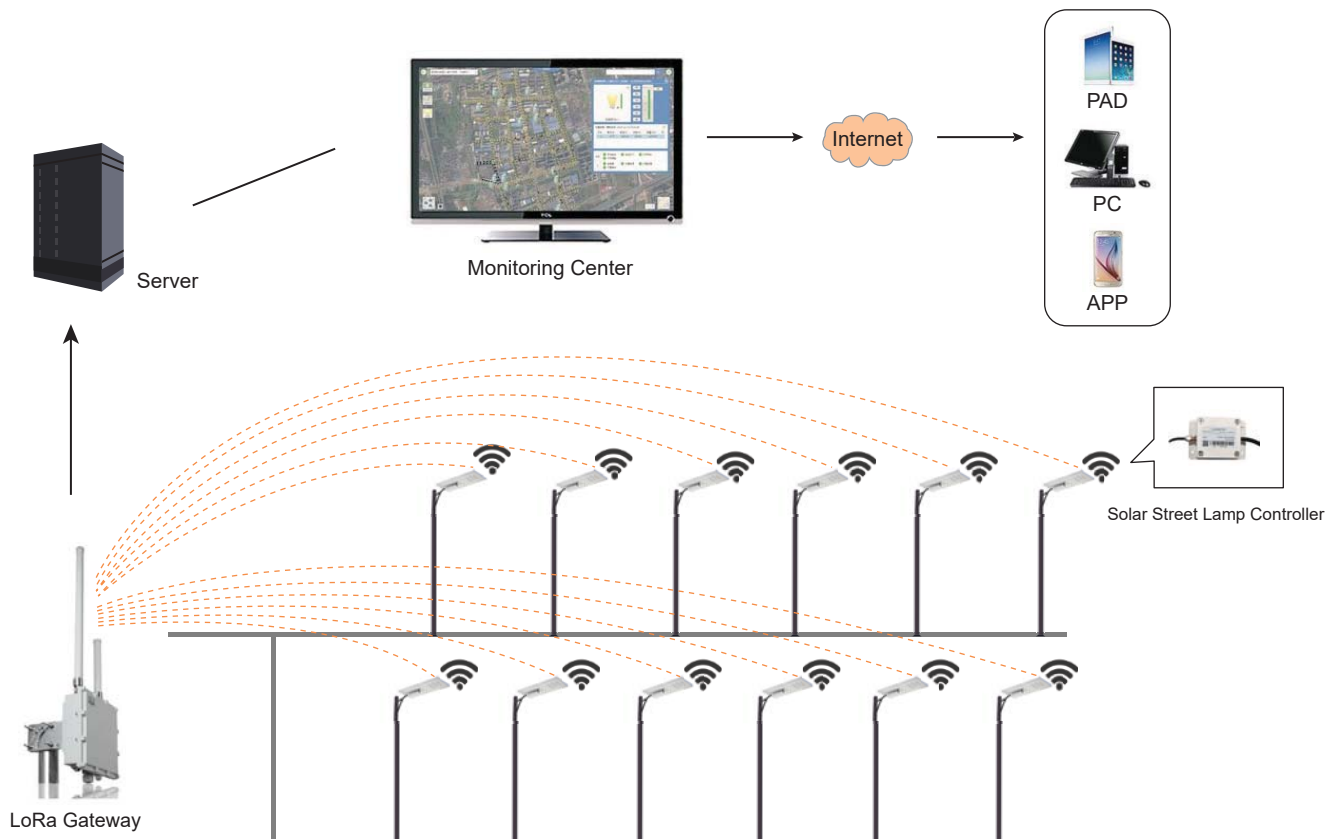
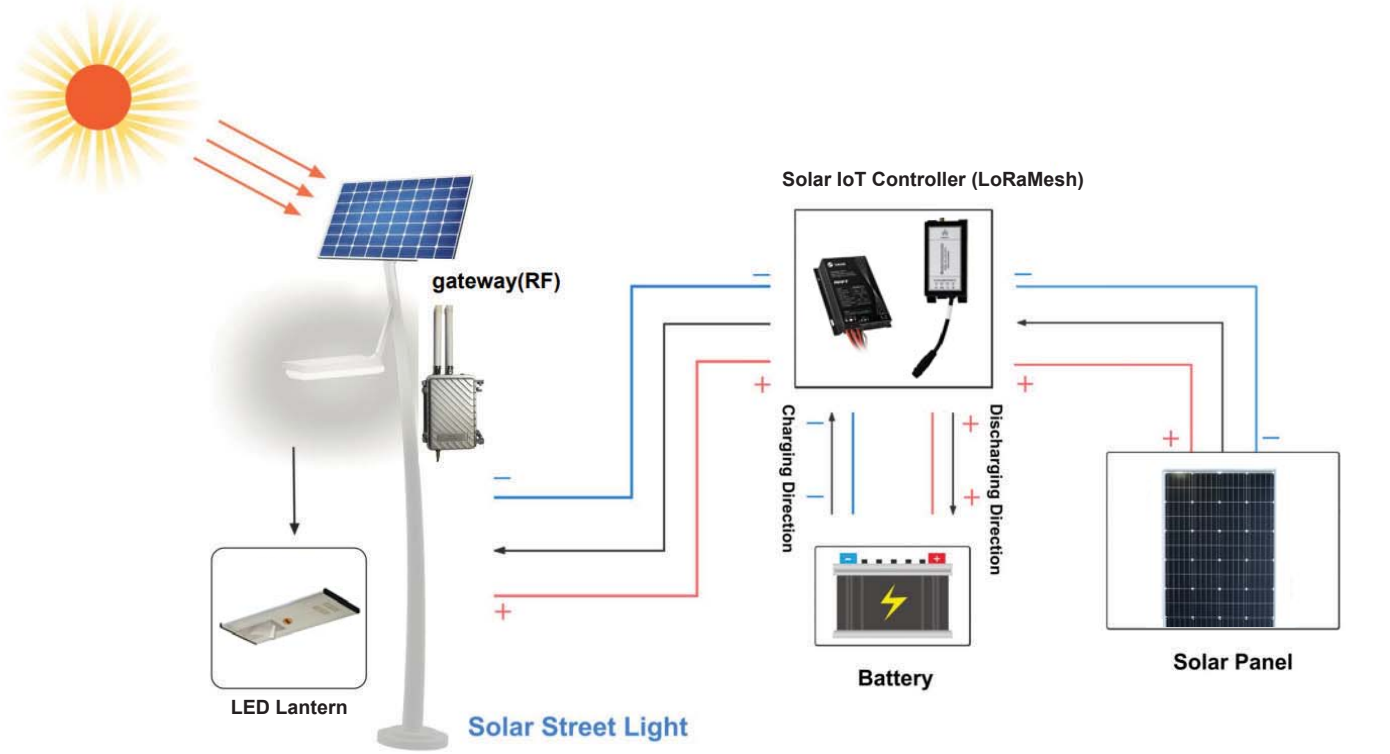

HARDWARE - GATEWAY

LoRaMesh Gateway



RTU500LDS-Z

Basic Information

DC Power Supply	Parameters	Minimum Value	Typical Value	Maximum Value
	Input Voltage (V)	9	12	36
Average Current (mA)	50	100	200	

Uplink Communication

Parameters		Minimum Value	Typical Value	Maximum Value
Bands	/	LTE-TDD ; LTE-FDD ; WCDMA ; GSM		
	TDD	B1/ B2/ B3/ B4/ B5/ B7/ B8/ B12/ B13/ B18/ B19/ B20/ B26/ B28		
	FDD	B38/ B40/ B41		
	WCDMA	B1/ B2/ B4/ B5/ B6/ B8/ B19		
	GSM	B2/ B3/ B5/ B8		
Transmit Power	dBm	23		30
Receiver Sensitivity	dBm	-98.5		-101dBm

Downlink Communication

Parameters		Minimum Value	Typical Value	Maximum Value
Bands	Hz	2.4G		2.5G
Transmit Power	dBm		12.5	
Receiver Sensitivity	dBm		-105	
Communication Mode	Dual band Communication, with separate frequency points for transmission and reception, ensuring no interference between them.			
Network Access Method	Autonomous Networking			

Working Environment

Parameter	Min	Typical	Max	Unit
Working Temperature	-40	25	85	°C
Relative Humidity	5		95	%
Weight	0.45			KG
Size (L*W*H)	230*190*75 (MAX)			mm

Accessory List

Name	Quantity	Remarks
Gateway	1	
LTE Antenna	1	Omni-directional Antenna
RF Antenna	1	2.4G Customized Antenna
Mounting Brackets	1	

HARDWARE - SOLAR LAMP CONTROLLER

Solar Lamp Controller



LCU51LDS-Z

Basic Information

Model		LCU51LDS-Z
DC Output	Input voltage range	4.0 - 5.5VDC
	static power	< 0.5W
	transient power	≤1W

Communication

Frequency	2.4G
Frequency range	2.4GHz — 2.5GHz
Power	12.5dBm±2dB
Sensitivity	-105dBm
Additional interface	RS485

Other Functions

Firmware update	Online, cable;
Frequency change	Automatic frequency search

Working Environment

Working temperature	-40 ~ +85°C
Storage temperature	-55°C ~ +125°C
Humid	<95%
Waterproof	IP65
Size	125*60*48 (mm)
Weight	0.1 KG

Dimensions

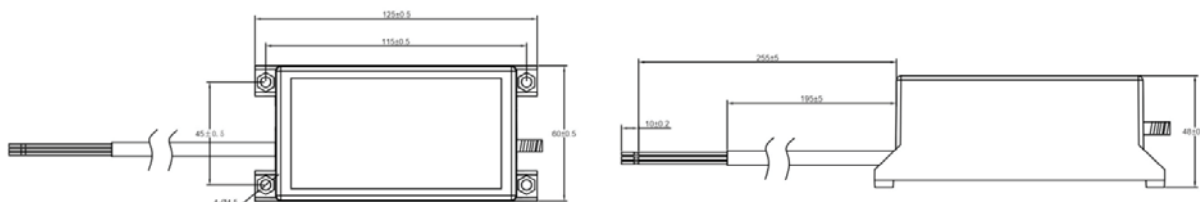

HARDWARE - MPPT Solar Light Controller

LoRaMesh MPPT Controller with LoRa Antenna



SR - DM60 - R/ W

SR - DM120 - R/ W

SR - DM160 - R/ W

SR - DM200 - R/ W

Specifications:

Items	Values				Adjustable	Default
	DM60	DM120	DM160	DM200		
Model	DM60	DM120	DM160	DM200		
Controller type	-R: infrared remote control; -W: 2.4G wireless remote control					
System voltage	12V	12V/ 24V				Lead-acid
Static power consumption	-R type: $\leq 5\text{mA}$	-R type: 6mA/ 12V; 4mA/ 24V		-R type: $\leq 10\text{mA}/ 12\text{V}; \leq 5\text{mA}/ 24\text{V}$		
	-W type: $\leq 20\text{mA}$	-W type: 18mA/ 12V; 13mA/ 24V		-W type: $\leq 25\text{mA}/ 12\text{V}; \leq 15\text{mA}/ 24\text{V}$		
Sleep power consumption	$\leq 1\text{mA}$					
Load current	50mA ~ 3000mA	50mA ~ 4200mA	50mA ~ 5600mA	150mA ~ 7000mA	√	330mA
Load voltage	15V ~ 50V	15V ~ 60V		15V ~ 75V		
Maximum load power	60W/ 12V	60W/ 12V; 120W/ 24V 80W/ 12V; 160W/24V 100W/ 12V; 200W/ 24V				
Load conversion efficiency	85% - 96% (Typical efficiency 95%)					
Load current accuracy	$\leq 3\% \pm 30\text{mA}$					
Intelligent power	High, Moderate, Low, Auto, USE, No				√	Medium
Load working period	9 - Period + Pre-dawn lighting					
Period adjustment range	1min / 10min					
Power adjustment range	1% / 10%					
Maximum solar input power	130W/ 12V	130W/ 12V ; 260W/ 24V 200W/ 12V ; 400W/ 24V 260W/ 12V ; 520W/ 24V				
Maximum charge current	10A		15A	20A		
Maximum solar input voltage	$\leq 50\text{V}$	$\leq 60\text{V}$		$\leq 100\text{V}$		
MPPT Tracking efficiency	$> 99\%$					
Charging conversion eff.	85% - 98% (Typical efficiency 97%)					

Parameter	Values				Adjustable	Default
Over voltage	PB - 16.0V; LI - overcharge voltage + 2V; × 2, 24V system					16.0V
Limited charge voltage	PB - 15.5V; LI - overcharge voltage + 1V; × 2, 24V system					15.5V
Equalizing charge voltage	PB - 14.6V; LI - None; ×2,24V system					14.6V
Equalizing charge interval	30 days					30D
Boost charge voltage (lead-acid)	8.5V ~ 17.0V ; ×2, 24V system				√	14.4V
Charge voltage (lithium)						
Floating charge voltage (lead-acid)	8.5V ~ 17.0V ; ×2, 24V system				√	13.8V
Charge return voltage (lithium)						
Over discharge voltage	8.5V ~ 17.0V ; ×2,24V system				√	11.0V
Over discharge return voltage	8.5V ~ 17.0V ; ×2,24V system				√	12.5V
Temperature compensation coefficient	PB: -3.0mV/ °C/ 2V; lithium battery: no compensation					
Light control voltage	3V ~ 11V ; ×2, 24V system				√	5V
Light control delay	0S ~ 60S/ 2min ~ 60min				√	10S
High temperature charge	+40°C ~ +90°C				√	65°C
Low temperature charge	0°C ~ -35°C				√	-35°C
Operating temperature	-35°C ~ +65°C					
IP rating	IP67					
Protections	Battery reverse polarity protection, solar panel reverse polarity protection, solar panel over-voltage protection, lithium battery overcharge and overdischarge protection, lithium battery BMS overcharge detection protection, over temperature protection, load open circuit and short circuit protection,					
Weight	260g	400g	5100g	770g		
Controller dimensions (mm)	80*82*22.6	114*82.3*24.5	142*82.3*24.5	155*114.4*34		
Controller mounting dimensions (mm)	65.5*75	82.3*74	82.3*102	102*123		
Mounting hole diameter (mm)	Φ 3.5					

A. Wiring diagram of the controller with built-in IoT module

B. Wiring diagram of the controller with external IoT module

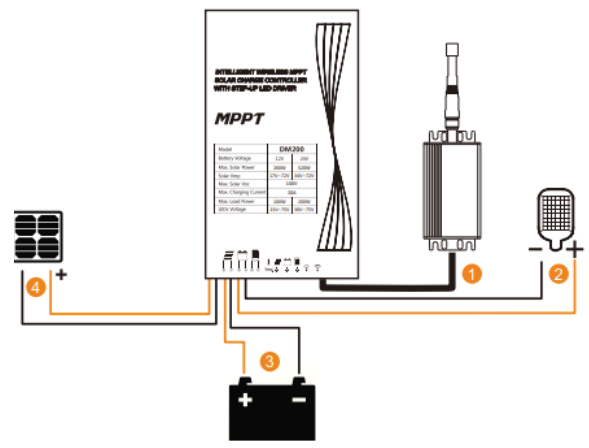
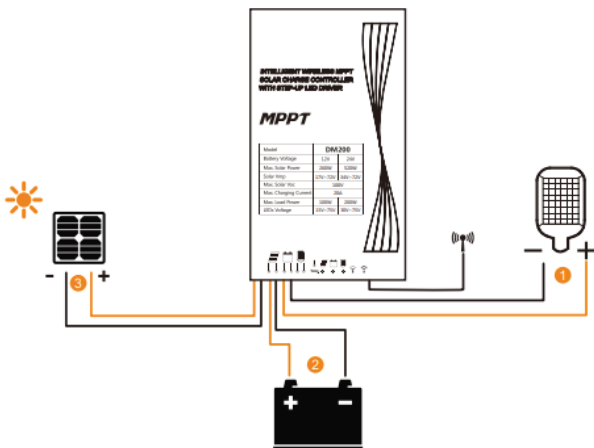

Note: The controller with antenna is a IoT type.



The communication line interfaces are defined as follows:

- Red VCC
- Black GND
- Yellow A/T
- White B/R

WEB PLATFORM / MOBILE APP

FOR SOLAR LED STREET LIGHTING

User friendly Interface

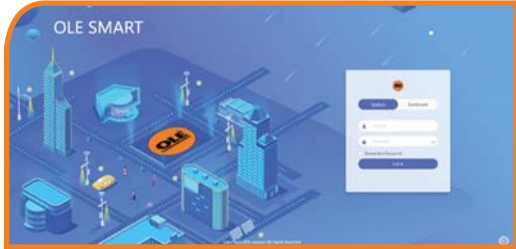

- Solar LED Lighting monitoring system



- Convenient management entry
- Multilingual choices
- Elegant design

Project management

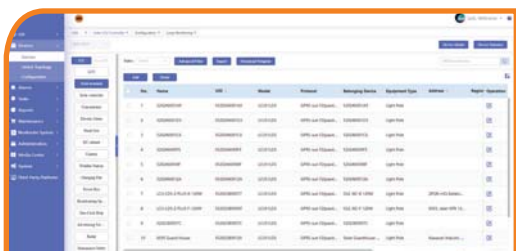

- Add device to the Project
- Add device information

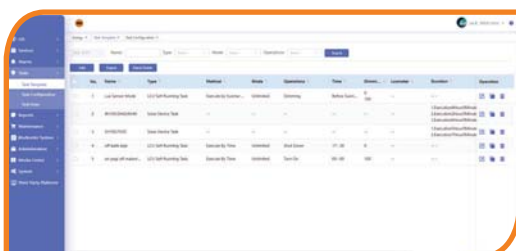

- Device parameter setting
- Duration and brightness setting

Geographic information system



- Based on the GIS system design
- 2D / 3D map
- Batch lamp control operation
- Lines & branches marked

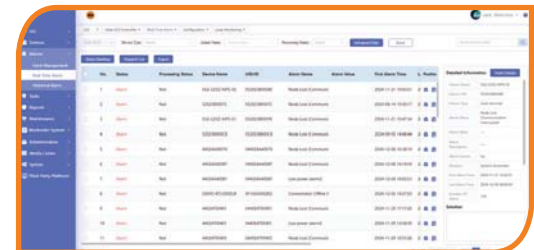

- Real-time alarm warning
- Quick positioning and facilities maintenance
- Equipment partition management
- Batch deployment capabilities

Status monitoring



- Monitors current device status
- Duration and brightness setting

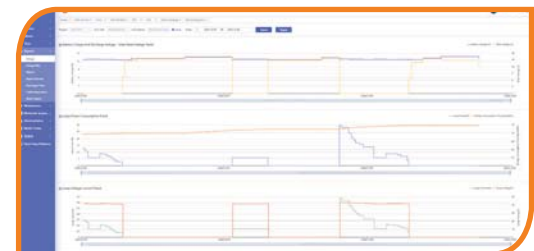

- Monitors battery charge and discharge voltage
- Monitors lamp power consumption trends
- Monitors lamp voltage current trendz

OLE Solar Shelter/ Floodlight



Model	Solar Flood Light 60W LED	Solar Flood Light 80W LED	Solar Flood Light 100W LED	Solar Flood Light 120W LED	Solar Flood Light 150W LED	Solar Flood Light 200W LED
Output and Capacity	60W	80W	100W	120W	150W	180W
	OLE NEP PRO					
	3000K - 6500K					
	38-42V, Constant Current Output					
Solar PV Panel	Monocrystalline Silicon					
	36V					
2 autonomy days	135W	135W	210W	210W	310W	310W
3 autonomy days	135W	135W	210W	210W	310W	310W
Battery	Lithium Battery					
	25.6V					
2 autonomy days	60AH	60AH	90AH	90AH	120AH	135AH
	1536WH	1536WH	2304WH	2304WH	3072WH	3456WH
3 autonomy days	75AH	90AH	120AH	135AH	180AH	210AH
	1920WH	2304WH	3072WH	3456WH	4608WH	5376WH
Charging Capacity	4.5 hours					
Dimming Schedule	4H 100% + 2H 60% + 6H 40%					
Smart Control and Monitoring	Optional					

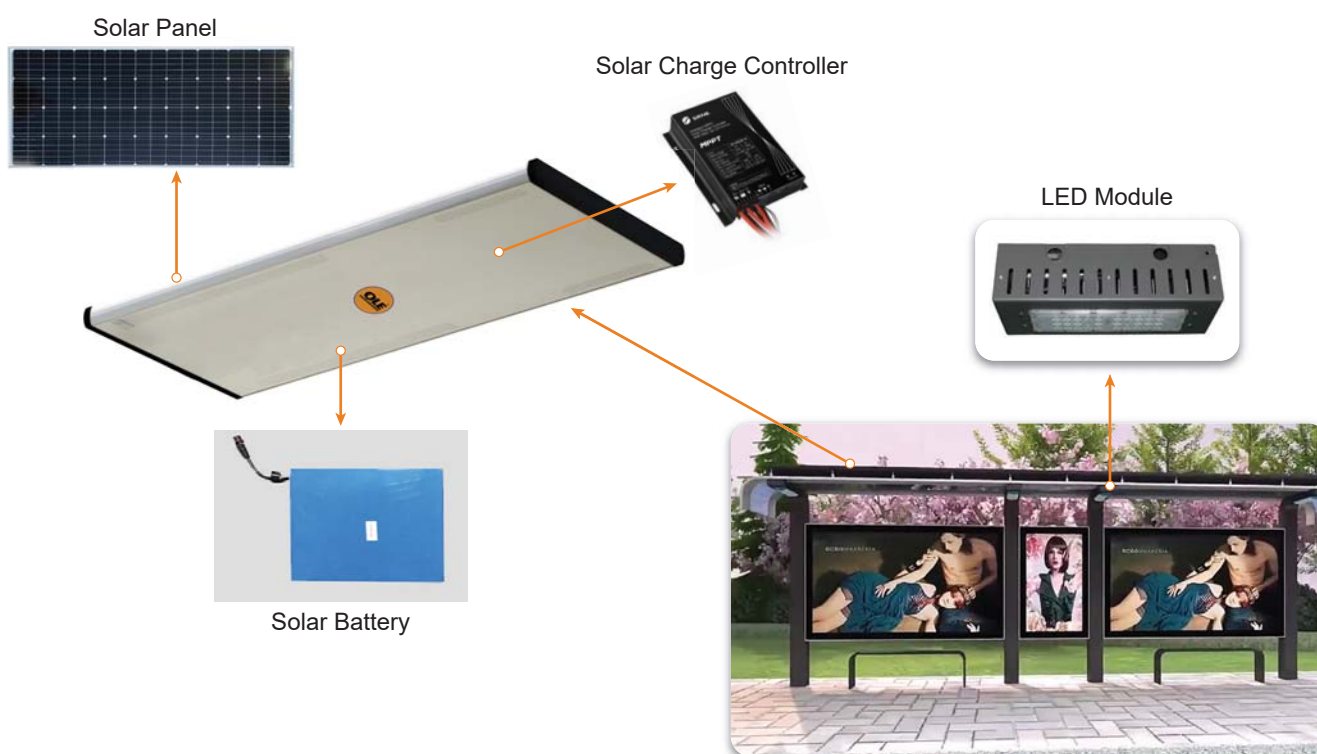

CERTIFICATE



Page 1 of 49



Report No.: LCSB05104019S001

TEST REPORT IEC 60598-2-3 Luminaires Part 2: Particular requirements Section 3: Luminaires for road and street lighting	
Report Number.....	LCSB05104019S001
Date of Issue.....	November 06, 2024
Total number of pages.....	49 pages
Name of Testing Laboratory preparing the Report.....	Shenzhen Southern LCS Compliance Testing Laboratory Ltd.
Applicant's name.....	OVERSEA LIGHTING & ELECTRIC (M) SDN BHD
Address.....	Lot 6595 & 6593, Jalan KP8 12B, Kawasan Industri Kg. Baru Balakong, 43300 Seri Kembangan, Selangor Darul Ehsan, Malaysia
Test specification:	
Standard.....	IEC 60598-2-3:2002, IEC 60598-2-3:2002/AMD1:2011 used in conjunction with IEC 60598-1:2020
Test procedure.....	Type test
Non-standard test method.....	N/A
TRF template used.....	IECEE OD-2020-F1:2021, Ed.1.4
Test Report Form No.....	IEC60598_2_3M
Test Report Form(s) Originator.....	Intertek Semko AB
Master TRF.....	2021-11-01
Copyright © 2021 IEC System of Conformity Assessment Schemes for Electrotechnical Equipment and Components (IECEE System). All rights reserved. This publication may be reproduced in whole or in part for non-commercial purposes as long as the IECEE is acknowledged as copyright owner and source of the material. IECEE takes no responsibility for and will not assume liability for damages resulting from the reader's interpretation of the reproduced material due to its placement and content. If this Test Report Form is used by non-IECEE members, the IECEE/IEC logo and the reference to the CB Scheme procedure shall be removed. This report is not valid as a CB Test Report unless signed by an approved IECEE Testing Laboratory and appended to a CB Test Certificate issued by an NCB in accordance with IECEE 02. General disclaimer: The test results presented in this report relate only to the object tested. This report shall not be reproduced, except in full, without the written approval of the Issuing NCB. The authenticity of this Test Report and its contents can be verified by contacting the NCB, responsible for this Test Report.	

Shenzhen Southern LCS Compliance Testing Laboratory Ltd.
Add: 101-201, No.39 Building, Xixiang Industrial Zone, Heshuikou Community, Matian Street, Guangming District, Shenzhen, China
Tel: +86 0755-29871520 | E-mail: webmaster@lcs-cert.com | Web: www.lcs-cert.com
Scan code to check authenticity



Page 1 of 53



Report No.: LCSB03294019S002

TEST REPORT IEC 60598-2-3 Luminaires Part 2: Particular requirements Section 3: Luminaires for road and street lighting	
Report Number.....	LCSB03294019S002
Date of Issue.....	December 12, 2024
Total number of pages.....	53 pages
Name of Testing Laboratory preparing the Report.....	Shenzhen Southern LCS Compliance Testing Co., Ltd.
Applicant's name.....	OVERSEA LIGHTING & ELECTRIC (M) SDN BHD
Address.....	Lot 6595 & 6593, Jalan KP8 12B, Kawasan Industri Kg. Baru Balakong, 43300 Seri Kembangan, Selangor Darul Ehsan, Malaysia
Test specification:	
Standard.....	IEC 60598-2-3:2002+A1:2011 used in conjunction with IEC 60598-1:2020
Test procedure.....	IEC Test Report
Non-standard test method.....	N/A
TRF template used.....	IECEE OD-2020-F1:2021, Ed.1.4
Test Report Form No.....	IEC60598_2_3M
Test Report Form(s) Originator.....	Intertek Semko AB
Master TRF.....	2021-11-01
Copyright © 2021 IEC System of Conformity Assessment Schemes for Electrotechnical Equipment and Components (IECEE System). All rights reserved. This publication may be reproduced in whole or in part for non-commercial purposes as long as the IECEE is acknowledged as copyright owner and source of the material. IECEE takes no responsibility for and will not assume liability for damages resulting from the reader's interpretation of the reproduced material due to its placement and content. If this Test Report Form is used by non-IECEE members, the IECEE/IEC logo and the reference to the CB Scheme procedure shall be removed. This report is not valid as a CB Test Report unless signed by an approved IECEE Testing Laboratory and appended to a CB Test Certificate issued by an NCB in accordance with IECEE 02. General disclaimer: The test results presented in this report relate only to the object tested. This report shall not be reproduced, except in full, without the written approval of the Issuing Testing Laboratory. The authenticity of this Test Report and its contents can be verified by contacting the Testing Laboratory, responsible for this Test Report.	

Shenzhen Southern LCS Compliance Testing Co., Ltd.
Add: Room 101-201, Building 39, Xixiang Industrial Zone, Heshuikou Community, Matian Street, Guangming District, Shenzhen, Guangdong, China
Tel: +86 0755-29871520 | E-mail: webmaster@lcs-cert.com | Web: www.lcs-cert.com
Scan code to check authenticity



Page 2 of 49

Report No.: LCSB05104019S001

Test item description.....	Integrated Solar Street Light
Trade Mark.....	N/A
Manufacturer.....	Same as applicant
Address.....	Same as applicant
Model/Type reference.....	JKC-K-60W
Ratings.....	DC 36V, 135Wh, 1x 45°C, IP65
Testing Laboratory.....	Shenzhen Southern LCS Compliance Testing Laboratory Ltd.
Testing location/ address.....	101-201, No.39 Building, Xixiang Industrial Zone, Heshuikou Community, Matian Street, Guangming District, Shenzhen, China
Checked by.....	Kim Chen (Engineer)
Check by.....	Tomas He (Director)
Approved by.....	Jesse Liu (Manager)
List of Attachments (including a total number of pages in each attachment):	Attachment No. 1: 1 pages of report IEC EN 62031. Attachment No. 2: 1 pages of report IEC TR 62778. Attachment No. 3: 4 pages of photo documentation.
Summary of testing:	
Tests performed (name of test and test clause):	IEC 60598-2-3:2002+A1:2011 IEC 60598-1:2020 IEC TR 62778:2014 IEC 62031:2018 IEC 62493:2015+A1:2022
Testing location:	Shenzhen Southern LCS Compliance Testing Laboratory Ltd. 101-201, No.39 Building, Xixiang Industrial Zone, Heshuikou Community, Matian Street, Guangming District, Shenzhen, China
Summary of compliance with National Differences:	List of countries addressed The product fulfils the requirements of Germany and European Group differences N/A



Page 3 of 49

Report No.: LCSB05104019S001

Copy of marking plate:
The artwork below may be only a draft. The use of certification marks on a product must be authorized by the respective NCBs that own these marks.

Integrated Solar Street Light Model: JKC-K-60W DC 36V, 135Wh Battery: 25.6Vdc, 45Ah, 1162Wh IP65 1x 45°C OVERSEA LIGHTING & ELECTRIC (M) SDN BHD Lot 6595 & 6593, Jalan KP8 12B, Kawasan Industri Kg. Baru Balakong, 43300 Seri Kembangan, Selangor Darul Ehsan, Malaysia

Remarks:
1. Representative markings of JKC-K-60W, markings of all models are identical except for the model name and rating.
2. Height of WEEE symbol should not less than 7mm, height of other marks at least 5mm, height of letters and numerals at least 2mm.



Page 2 of 53

Report No.: LCSB03294019S002

Test item description.....	Integrated Solar Street Light
Trade Mark.....	N/A
Manufacturer.....	OVERSEA LIGHTING & ELECTRIC (M) SDN BHD
Address.....	Lot 6595 & 6593, Jalan KP8 12B, Kawasan Industri Kg. Baru Balakong, 43300 Seri Kembangan, Selangor Darul Ehsan, Malaysia
Model/Type reference.....	JKC-K-60W
Ratings.....	DC36V, 80Wh, 1x 45°C, IP65
Testing Laboratory.....	Shenzhen Southern LCS Compliance Testing Co., Ltd.
Testing location/ address.....	Room 101-201, Building 39, Xixiang Industrial Zone, Heshuikou Community, Matian Street, Guangming District, Shenzhen, Guangdong, China
Completed by.....	Roberto Qin (Engineer)
Check by.....	Tomas He (Director)
Approved by.....	Jesse Liu (Manager)
List of Attachments (including a total number of pages in each attachment):	Attachment No. 2: 2 pages of report IEC 62031. Attachment No. 3: 1 pages of report IEC TR 62778. Attachment No. 4: Photo documentation.
Summary of testing:	
Tests performed (name of test and test clause):	IEC 60598-2-3:2002+A1:2011 IEC 60598-1:2020 IEC TR 62778: 2014 IEC 62031:2018 IEC 62493:2015+A1:2022
Testing location:	Shenzhen Southern LCS Compliance Testing Co., Ltd. Room 101-201, Building 39, Xixiang Industrial Zone, Heshuikou Community, Matian Street, Guangming District, Shenzhen, Guangdong, China



Page 3 of 53

Report No.: LCSB03294019S002

Copy of marking plate:
The artwork below may be only a draft. The use of certification marks on a product must be authorized by the respective NCBs that own these marks.

Integrated Solar Street Light Model: JKC-K-60W Rated Voltage: DC36V Rated Wattage: 80W Battery: 25.6V, 80Ah, 1536Wh IP65 1x45°C OVERSEA LIGHTING & ELECTRIC (M) SDN BHD Lot 6595 & 6593, Jalan KP8 12B, Kawasan Industri Kg. Baru Balakong, 43300 Seri Kembangan, Selangor Darul Ehsan, Malaysia

Remarks:
1. Representative markings of JKC-K-60W, markings of all models are identical except for the model name.
2. Height of CE mark at least 5mm, height of WEEE symbol should not less than 7mm, height of other marks at least 5mm, height of letters and numerals at least 2mm.

CERTIFICATE



Page 1 of 49



Report No.: LCSB05104018S001

1 TEST REPORT
IEC 60598-2-3
Luminaires
Part 2: Particular requirements
Section 3: Luminaires for road and street lighting

Report Number: LCSB05104018S001
Date of issue: November 06, 2024
Total number of pages: 49 pages

Name of Testing Laboratory preparing the Report: Shenzhen Southern LCS Compliance Testing Laboratory Ltd.
Applicant's name: OVERSEA LIGHTING & ELECTRIC (M) SDN BHD
Address: Lot 6595 & 6593, Jalan KP8 12B, Kawasan Industri Kg. Baru Balakong, 43300 Seri Kembangan, Selangor Darul Ehsan, Malaysia

Test specification:
Standard: IEC 60598-2-3:2002, IEC 60598-2-3:2002/AMD1:2011 used in conjunction with IEC 60598-1:2020
Test procedure: Type test
Non-standard test method: N/A

TRF template used: IECEE OD-2020-F1:2021, Ed.1.4
Test Report Form No.: IEC60598_2_3M
Test Report Form(s) Originator: Intertek Semko AB
Master TRF: 2021-11-01

Copyright © 2021 IEC System of Conformity Assessment Schemes for Electrotechnical Equipment and Components (IECEE System). All rights reserved.
This publication may be reproduced in whole or in part for non-commercial purposes as long as the IECEE is acknowledged as copyright owner and source of the material. IECEE takes no responsibility for and will not assume liability for damages resulting from the reader's interpretation of the reproduced material due to its placement and content.
If this Test Report Form is used by non-IECEE members, the IECEE/IEC logo and the reference to the CB Scheme procedure shall be removed.
This report is not valid as a CB Test Report unless signed by an approved IECEE Testing Laboratory and appended to a CB Test Certificate issued by an NCB in accordance with IECEE 02.

General disclaimer:
The test results presented in this report relate only to the object tested.
This report shall not be reproduced, except in full, without the written approval of the Issuing NCB. The authenticity of this Test Report and its contents can be verified by contacting the NCB, responsible for this Test Report.

Shenzhen Southern LCS Compliance Testing Laboratory Ltd.
Add: 101-201, No.39 Building, Xialang Industrial Zone, Heshukou Community, Matian Street, Guangming District, Shenzhen, China
Tel: +86 0755-29671520 | E-mail: webmaster@lcs-cert.com | Web: www.lcs-cert.com
Scan code to check authenticity



Page 1 of 48



Report No.: LCSB03294023S001

TEST REPORT
IEC 60598-2-3
Luminaires
Part 2: Particular requirements
Section 3: Luminaires for road and street lighting

Report Number: LCSB03294023S001
Date of issue: November 06, 2024
Total number of pages: 47 pages

Name of Testing Laboratory preparing the Report: Shenzhen Southern LCS Compliance Testing Laboratory Ltd.
Applicant's name: OVERSEA LIGHTING & ELECTRIC (M) SDN BHD
Address: Lot 6595 & 6593, Jalan KP8 12B, Kawasan Industri Kg. Baru Balakong, 43300 Seri Kembangan, Selangor Darul Ehsan, Malaysia

Test specification:
Standard: IEC 60598-2-3:2002, IEC 60598-2-3:2002/AMD1:2011 used in conjunction with IEC 60598-1:2020
Test procedure: Type test
Non-standard test method: N/A

TRF template used: IECEE OD-2020-F1:2021, Ed.1.4
Test Report Form No.: IEC60598_2_3M
Test Report Form(s) Originator: Intertek Semko AB
Master TRF: 2021-11-01

Copyright © 2021 IEC System of Conformity Assessment Schemes for Electrotechnical Equipment and Components (IECEE System). All rights reserved.
This publication may be reproduced in whole or in part for non-commercial purposes as long as the IECEE is acknowledged as copyright owner and source of the material. IECEE takes no responsibility for and will not assume liability for damages resulting from the reader's interpretation of the reproduced material due to its placement and content.
If this Test Report Form is used by non-IECEE members, the IECEE/IEC logo and the reference to the CB Scheme procedure shall be removed.
This report is not valid as a CB Test Report unless signed by an approved IECEE Testing Laboratory and appended to a CB Test Certificate issued by an NCB in accordance with IECEE 02.

General disclaimer:
The test results presented in this report relate only to the object tested.
This report shall not be reproduced, except in full, without the written approval of the Issuing NCB. The authenticity of this Test Report and its contents can be verified by contacting the NCB, responsible for this Test Report.

Shenzhen Southern LCS Compliance Testing Laboratory Ltd.
Add: 101-201, No.39 Building, Xialang Industrial Zone, Heshukou Community, Matian Street, Guangming District, Shenzhen, China
Tel: +86 0755-29671520 | E-mail: webmaster@lcs-cert.com | Web: www.lcs-cert.com
Scan code to check authenticity



Page 2 of 49

Report No.: LCSB05104018S001

Test item description: Integrated Solar Street Light
Trade Mark: N/A
Manufacturer: Same as applicant
Address: Same as applicant
Model/Type reference: JKC-K-100W
Rating: DC 36V, 210W, ta 45°C, IP65

Testing Laboratory: Shenzhen Southern LCS Compliance Testing Laboratory Ltd.
Testing location/ address: Shenzhen Southern LCS Compliance Testing Laboratory Ltd, 101-201, No.39 Building, Xialang Industrial Zone, Heshukou Community, Matian Street, Guangming District, Shenzhen, China

Tested by: Kim Chen (Engineer)
Checked by: Tomes He (Director)
Approved by: Jesse Liu (Manager)

List of Attachments (including a total number of pages in each attachment):
Attachment No. 1: 1 pages of report IECEN 62031
Attachment No. 2: 1 pages of report IEC TR 62778
Attachment No. 3: 4 pages of photo documentation.

Summary of testing:
Tests performed (name of test and test clause): IEC 60598-2-3:2002-A1:2011, IEC 60598-1:2020, IEC TR 62778:2014, IEC 62031:2018, IEC 62493:2015-A1:2022
Testing location: Shenzhen Southern LCS Compliance Testing Laboratory Ltd, 101-201, No.39 Building, Xialang Industrial Zone, Heshukou Community, Matian Street, Guangming District, Shenzhen, China

Summary of compliance with National Differences:
List of countries addressed: The product fulfils the requirements of Germany and European Group differences
N/A



Page 2 of 49

Report No.: LCSB05104018S001

Copy of marking plate:
The artwork below may be only a draft. The use of certification marks on a product must be authorized by the respective NCBs that own these marks.

Integrated Solar Street Light
Model: JKC-K-100W
DC 36V, 210W
Battery: 25.6Vdc 75Ah 1920Wh
IP65 ta 45°C
OVERSEA LIGHTING & ELECTRIC (M) SDN BHD
Lot 6595 & 6593, Jalan KP8 12B, Kawasan Industri Kg. Baru Balakong, 43300 Seri Kembangan, Selangor Darul Ehsan, Malaysia

Remarks:
1. Representative markings of JKC-K-100W, markings of all models are identical except for the model name and rating.
2. Height of WEEE symbol should not less than 7mm, height of other marks at least 5mm, height of letters and numerals at least 2mm.



Page 2 of 48

Report No.: LCSB03294023S001

Test item description: Integrated Solar Street Light
Trade Mark: N/A
Manufacturer: Same as applicant
Address: Same as applicant
Model/Type reference: See model list
Rating: DC36V, 210W, ta 45°C, IP65

Testing Laboratory: Shenzhen Southern LCS Compliance Testing Laboratory Ltd.
Testing location/ address: Shenzhen Southern LCS Compliance Testing Laboratory Ltd, 101-201, No.39 Building, Xialang Industrial Zone, Heshukou Community, Matian Street, Guangming District, Shenzhen, China

Tested by: Kim Chen (Engineer)
Checked by: Tomes He (Director)
Approved by: Jesse Liu (Manager)

List of Attachments (including a total number of pages in each attachment):
Attachment No. 1: 1 pages of report IECEN 62031
Attachment No. 2: 1 pages of report IEC TR 62778
Attachment No. 3: 4 pages of photo documentation.

Summary of testing:
Tests performed (name of test and test clause): IEC 60598-2-3:2002-A1:2011, IEC 60598-1:2020, IEC TR 62778:2014, IEC 62031:2018, IEC 62493:2015-A1:2022
Testing location: Shenzhen Southern LCS Compliance Testing Laboratory Ltd, 101-201, No.39 Building, Xialang Industrial Zone, Heshukou Community, Matian Street, Guangming District, Shenzhen, China

Summary of compliance with National Differences:
List of countries addressed: The product fulfils the requirements of Germany and European Group differences
N/A



Page 3 of 48

Report No.: LCSB03294023S001

Copy of marking plate:
The artwork below may be only a draft. The use of certification marks on a product must be authorized by the respective NCBs that own these marks.

Integrated Solar Street Light
Model: JKC-K-120W
DC36V, 210W
Battery: 25.6Vdc 90Ah 2304Wh
IP65 ta 45°C
OVERSEA LIGHTING & ELECTRIC (M) SDN BHD
Lot 6595 & 6593, Jalan KP8 12B, Kawasan Industri Kg. Baru Balakong, 43300 Seri Kembangan, Selangor Darul Ehsan, Malaysia

Remarks:
1. Representative markings of JKC-K-120W, markings of all models are identical except for the model name and rating.
2. Height of WEEE symbol should not less than 7mm, height of other marks at least 5mm, height of letters and numerals at least 2mm.

CERTIFICATE



Page 1 of 48



Report No.: LCSB032940225001

TEST REPORT
IEC 60598-2-3
Luminaires
Part 2: Particular requirements
Section 3: Luminaires for road and street lighting

Report Number: LCSB032940225001
Date of Issue: November 06, 2024
Total number of pages: 48 pages

Name of Testing Laboratory preparing the Report: Shenzhen Southern LCS Compliance Testing Laboratory Ltd.
Applicant's name: OVERSEA LIGHTING & ELECTRIC (M) SDN BHD
Address: Lot 6595 & 6593, Jalan KP8 12B, Kawasan Industri Kg. Baru Bataikong, 43300 Seri Kembangan, Selangor Darul Ehsan, Malaysia

Test specification:
Standard: IEC 60598-2-3:2002, IEC 60598-2-3:2002/AMD1:2011 used in conjunction with IEC 60598-1:2020
Test procedure: Type test
Non-standard test method: N/A
TRF template used: IEC60598_2_3M
Test Report Form No.: IEC60598_2_3M
Test Report Form(s) Originator: Intertek Semko AB
Master TRF: 2021-11-01

Copyright © 2021 IEC System of Conformity Assessment Schemes for Electrotechnical Equipment and Components (IECEE System). All rights reserved.
This publication may be reproduced in whole or in part for non-commercial purposes as long as the IECEE is acknowledged as copyright owner and source of the material. IECEE takes no responsibility for and will not assume liability for damages resulting from the reader's interpretation of the reproduced material due to its placement and context.
If this Test Report Form is used by non-IECEE members, the IECEE/IEC logo and the reference to the CB Scheme procedure shall be removed.
This report is not valid as a CB Test Report unless signed by an approved IECEE Testing Laboratory and appended to a CB Test Certificate issued by an NCB in accordance with IECEE 02.
General disclaimer:
The test results presented in this report relate only to the object tested.
This report shall not be reproduced, except in full, without the written approval of the Issuing NCB. The authenticity of this Test Report and its contents can be verified by contacting the NCB, responsible for this Test Report.

Shenzhen Southern LCS Compliance Testing Laboratory Ltd.
Add: 101-201, No.39 Building, Xixiang Industrial Zone, Heshikou Community, Matian Street, Guangming District, Shenzhen, China
Tel: +86) 0755-29871520 | E-mail: webmaster@lcs-cert.com | Web: www.lcs-cert.com
Scan code to check authenticity



Page 2 of 48

Report No.: LCSB032940225001

Test item description: Integrated Solar Street Light
Trade Mark: N/A
Manufacturer: Same as applicant
Address: Same as applicant
Model/Type reference: Same model list
Ratings: DC 36V, 310W, ta 45°C, IP65

Testing Laboratory: Shenzhen Southern LCS Compliance Testing Laboratory Ltd.
Testing location/ address: Shenzhen Southern LCS Compliance Testing Laboratory Ltd, Room 101-201, Building 39, Xixiang Industrial Zone, Heshikou Community, Matian Street, Guangming District, Shenzhen, China
Tested by: Kim Chen (Engineer)
Check by: Torres He (Director)
Approved by: Jesse Liu (Manager)

List of Attachments (including a total number of pages in each attachment):
Attachment No. 1: 1 pages of report IEC60501
Attachment No. 2: 1 pages of report IEC TR 62778
Attachment No. 3: 4 pages of photo documentation

Summary of testing:
Tests performed (name of test and test clause): IEC 60598-2-3:2002+A1:2011 IEC 60598-1:2020 IEC TR 62778:2014 IEC 62031:2018 IEC 62493:2015+A1:2022
Testing location: Shenzhen Southern LCS Compliance Testing Laboratory Ltd, Room 101-201, Building 39, Xixiang Industrial Zone, Heshikou Community, Matian Street, Guangming District, Shenzhen, China

Summary of compliance with National Differences:
List of countries addressed: N/A
The product fulfils the requirements of Germany and European Group differences: N/A



Page 3 of 48

Report No.: LCSB032940225001

Copy of marking plate:
The artwork below may be only a draft. The use of certification marks on a product must be authorized by the respective NCBs that own these marks.

Integrated Solar Street Light
Model: JKC-K-150W
DC 36V, 310W
Battery: 25.6V 120Ah 3072Wh
IP65 ta 45°C
OVERSEA LIGHTING & ELECTRIC (M) SDN BHD
Lot 6595 & 6593, Jalan KP8 12B, Kawasan Industri Kg. Baru Bataikong, 43300 Seri Kembangan, Selangor Darul Ehsan, Malaysia

Remarks:
1. Representative markings of JKC-K-150W, markings of all models are identical except for the model name and rating.
2. Height of WEEE symbol should not less than 7mm, height of other marks at least 5mm, height of letters and numerals at least 2mm.



Report No.: LCSB032940205001

TEST REPORT
IEC 60598-2-3
Luminaires
Part 2: Particular requirements
Section 3: Luminaires for road and street lighting

Report Number: LCSB032940205001
Date of Issue: September 19, 2024
Total number of pages: 53 pages

Name of Testing Laboratory preparing the Report: Shenzhen Southern LCS Compliance Testing Co., Ltd.
Applicant's name: OVERSEA LIGHTING & ELECTRIC (M) SDN BHD
Address: Lot 6595 & 6593, Jalan KP8 12B, Kawasan Industri Kg. Baru Bataikong, 43300 Seri Kembangan, Selangor Darul Ehsan, Malaysia

Test specification:
Standard: IEC 60598-2-3:2002+A1:2011 used in conjunction with IEC 60598-1:2020
Test procedure: IEC Test Report
Non-standard test method: N/A
TRF template used: IEC60598_2_3M
Test Report Form No.: IEC60598_2_3M
Test Report Form(s) Originator: Intertek Semko AB
Master TRF: 2021-11-01

Copyright © 2021 IEC System of Conformity Assessment Schemes for Electrotechnical Equipment and Components (IECEE System). All rights reserved.
This publication may be reproduced in whole or in part for non-commercial purposes as long as the IECEE is acknowledged as copyright owner and source of the material. IECEE takes no responsibility for and will not assume liability for damages resulting from the reader's interpretation of the reproduced material due to its placement and context.
If this Test Report Form is used by non-IECEE members, the IECEE/IEC logo and the reference to the CB Scheme procedure shall be removed.
This report is not valid as a CB Test Report unless signed by an approved IECEE Testing Laboratory and appended to a CB Test Certificate issued by an NCB in accordance with IECEE 02.
General disclaimer:
The test results presented in this report relate only to the object tested.
This report shall not be reproduced, except in full, without the written approval of the Issuing Testing Laboratory. The authenticity of this Test Report and its contents can be verified by contacting the Testing Laboratory, responsible for this Test Report.

Shenzhen Southern LCS Compliance Testing Co., Ltd.
Add: Room 101-201, Building 39, Xixiang Industrial Zone, Heshikou Community, Matian Street, Guangming District, Shenzhen, Guangdong, China
Tel: +86) 0755-29871520 | E-mail: webmaster@lcs-cert.com | Web: www.lcs-cert.com
Scan code to check authenticity



Page 2 of 53

Report No.: LCSB032940205001

Test item description: Integrated Solar Street Light
Trade Mark: N/A
Manufacturer: OVERSEA LIGHTING & ELECTRIC (M) SDN BHD
Address: Lot 6595 & 6593, Jalan KP8 12B, Kawasan Industri Kg. Baru Bataikong, 43300 Seri Kembangan, Selangor Darul Ehsan, Malaysia
Model/Type reference: JKC-F-120W
Ratings: DC36V, 120W, ta 45°C, IP65

Testing Laboratory: Shenzhen Southern LCS Compliance Testing Co., Ltd.
Testing location/ address: Shenzhen Southern LCS Compliance Testing Co., Ltd, Room 101-201, Building 39, Xixiang Industrial Zone, Heshikou Community, Matian Street, Guangming District, Shenzhen, Guangdong, China
Compiled by: Rebecca Qin (Engineer)
Check by: Torres He (Director)
Approved by: Jesse Liu (Manager)

List of Attachments (including a total number of pages in each attachment):
Attachment No. 2: 2 pages of report IEC 62031
Attachment No. 3: 1 pages of report IEC TR 62778
Attachment No. 4: Photo documentation

Summary of testing:
Tests performed (name of test and test clause): IEC 60598-2-3:2002+A1:2011 IEC 60598-1:2020 IEC TR 62778:2014 IEC 62031:2018 IEC 62493:2015+A1:2022
Testing location: Shenzhen Southern LCS Compliance Testing Co., Ltd, Room 101-201, Building 39, Xixiang Industrial Zone, Heshikou Community, Matian Street, Guangming District, Shenzhen, Guangdong, China



Page 3 of 53

Report No.: LCSB032940205001

Copy of marking plate:
The artwork below may be only a draft. The use of certification marks on a product must be authorized by the respective NCBs that own these marks.

Integrated Solar Street Light
Model: JKC-F-120W
Rated Voltage: DC36V
Rated Wattage: 120W
Battery: 25.6V, 210Ah, 5376Wh
IP65 ta 45°C
OVERSEA LIGHTING & ELECTRIC (M) SDN BHD
Lot 6595 & 6593, Jalan KP8 12B, Kawasan Industri Kg. Baru Bataikong, 43300 Seri Kembangan, Selangor Darul Ehsan, Malaysia

Remarks:
1. Representative markings of JKC-F-120W, markings of all models are identical except for the model name.
2. Height of CE mark at least 5mm, height of WEEE symbol should not less than 7mm, height of other marks at least 5mm, height of letters and numerals at least 2mm.

CERTIFICATE



TEST REPORT IEC 60598-2-3 Luminaires Part 2: Particular requirements Section 3: Luminaires for road and street lighting	
Report Number.....	LCSB03294021S001
Date of issue.....	September 19, 2024
Total number of pages.....	54 pages
Name of Testing Laboratory preparing the Report.....	Shenzhen Southern LCS Compliance Testing Co., Ltd.
Applicant's name.....	OVERSEA LIGHTING & ELECTRIC (M) SDN BHD
Address.....	Lot 6595 & 6593, Jalan KPB 12B, Kawasan Industri Kg. Baru Balakong, 43300 Seri Kembangan, Selangor Darul Ehsan, Malaysia
Test specification:	
Standard.....	IEC 60598-2-3:2002+A1:2011 used in conjunction with IEC 60598-1:2020
Test procedure.....	IEC Test Report
Non-standard test method.....	N/A
TRF template used.....	IECEE OD-2020-F1:2021, Ed.1.4
Test Report Form No.....	IEC60598_2_3M
Test Report Form(s) Originator.....	Intertek Semko AB
Master TRF.....	2021-11-01
Copyright © 2021 IEC System of Conformity Assessment Schemes for Electrotechnical Equipment and Components (IECEE System). All rights reserved. This publication may be reproduced in whole or in part for non-commercial purposes as long as the IECEE is acknowledged as copyright owner and source of the material. IECEE takes no responsibility for and will not assume liability for damages resulting from the reader's interpretation of the reproduced material due to its placement and content. If this Test Report Form is used by non-IECEE members, the IECEE/IEC logo and the reference to the CB Scheme procedure shall be removed. This report is not valid as a CB Test Report unless signed by an approved IECEE Testing Laboratory and appended to a CB Test Certificate issued by an NCB in accordance with IECEE 02.	
General disclaimer: The test results presented in this report relate only to the object tested. This report shall not be reproduced, except in full, without the written approval of the Issuing Testing Laboratory. The authenticity of this Test Report and its contents can be verified by contacting the Testing Laboratory, responsible for this Test Report.	

Shenzhen Southern LCS Compliance Testing Laboratory Ltd.
Add: Room 101-201, Building 39, Xiliang Industrial Zone, Heshukou Community, Matian Street, Guangming District, Shenzhen, Guangdong, China
Tel: +86 (0) 755-26871520 | E-mail: webmaster@lcs-cert.com | Web: www.lcs-cert.com
Scan code to check authenticity



Test item description.....	Integrated Solar Street Light
Trade Mark.....	N/A
Manufacturer.....	OVERSEA LIGHTING & ELECTRIC (M) SDN BHD
Address.....	Lot 6595 & 6593, Jalan KPB 12B, Kawasan Industri Kg. Baru Balakong, 43300 Seri Kembangan, Selangor Darul Ehsan, Malaysia
Model/Type reference.....	JKC-F-150W
Rating.....	DC36V, 150W, ta,45°C, IP65
Testing Laboratory:	Shenzhen Southern LCS Compliance Testing Co., Ltd. Room 101-201, Building 39, Xiliang Industrial Zone, Heshukou Community, Matian Street, Guangming District, Shenzhen, Guangdong, China
Compiled by.....	Rebecca Qin (Engineer)
Check by.....	Torres Ho (Director)
Approved by.....	Jesse Liu (Manager)
List of Attachments (including a total number of pages in each attachment): Attachment No. 2: 2 pages of report IEC 62031. Attachment No. 3: 1 pages of report IEC TR 62778. Attachment No. 4: Photo documentation.	
Summary of testing:	
Tests performed (name of test and test clause): IEC 60598-2-3:2002+A1:2011 IEC 60598-1:2020 IEC TR 62778: 2014 IEC 62031:2016 IEC 62493:2015+A1:2022	Testing location: Shenzhen Southern LCS Compliance Testing Co., Ltd. Room 101-201, Building 39, Xiliang Industrial Zone, Heshukou Community, Matian Street, Guangming District, Shenzhen, Guangdong, China



Copy of marking plate: The artwork below may be only a draft. The use of certification marks on a product must be authorized by the respective NCBs that own these marks.		
<table border="1"> <tbody> <tr> <td> Integrated Solar Street Light Model: JKC-F-150W Rated Voltage: DC36V Rated Wattage: 150W Battery: 25.6V, 270Ah, 6912Wh IP65 ta45°C OVERSEA LIGHTING & ELECTRIC (M) SDN BHD Lot 6595 & 6593, Jalan KPB 12B, Kawasan Industri Kg. Baru Balakong, 43300 Seri Kembangan, Selangor Darul Ehsan, Malaysia </td> </tr> </tbody> </table>		Integrated Solar Street Light Model: JKC-F-150W Rated Voltage: DC36V Rated Wattage: 150W Battery: 25.6V, 270Ah, 6912Wh IP65 ta45°C OVERSEA LIGHTING & ELECTRIC (M) SDN BHD Lot 6595 & 6593, Jalan KPB 12B, Kawasan Industri Kg. Baru Balakong, 43300 Seri Kembangan, Selangor Darul Ehsan, Malaysia
Integrated Solar Street Light Model: JKC-F-150W Rated Voltage: DC36V Rated Wattage: 150W Battery: 25.6V, 270Ah, 6912Wh IP65 ta45°C OVERSEA LIGHTING & ELECTRIC (M) SDN BHD Lot 6595 & 6593, Jalan KPB 12B, Kawasan Industri Kg. Baru Balakong, 43300 Seri Kembangan, Selangor Darul Ehsan, Malaysia		
Remarks: 1. Representative markings of JKC-F-150W, markings of all models are identical except for the model name. 2. Height of CE mark at least 5mm, height of WEEE symbol should not less than 7mm, height of other marks at least 5mm, height of letters and numerals at least 2mm.		

CERTIFICATE

No.GF2400845

Guangdong Testing Institute of Product Quality Supervision
China National Quality Testing and Inspection Center for Solar Energy Photovoltaic Products (Guangdong)

TEST REPORT



Random number: EYA2173

Page 1 of 13

Name of product	Crystalline silicon photovoltaic modules	Date of manufacturing/expiry	-----
Type/ Specification	36V 135W, 36V 210W	Batch No.	-----
Inspected Unit	-----	No. of testing/sampling plan	257622
Address of inspected unit	-----	Test Type	Commission
Applicant	OVERSEA LIGHTING & ELECTRIC(M) SDN BHD	Sampling Location	-----
Factory	-----	Basic Quantity of Sampling	-----
Address of factory	-----	Way of sample incoming	-----/-----
Quantity of sample	2 pcs	Date of receipt of sample / sampling	2024-10-24
Status of sample	-----	Tested Date	2024-12-12
Testing reference	IEC 61215-2:2021 Terrestrial photovoltaic (PV) modules – Design qualification and type approval - Part 2: Test procedures		
Judgment reference	IEC 61215-2:2021 Terrestrial photovoltaic (PV) modules – Design qualification and type approval - Part 2: Test procedures		
Conclusion	Damp heat test meets the requirements of the Judgment reference.		
Notes	-----		

Approved by:

Reviewed by:

Tested by:

Official testing stamp of the institute

Date of issue : 2024-12-12

检验检测专用章

(S2)

CERTIFICATE

No.GF2400633

Guangdong Testing Institute of Product Quality Supervision
China National Quality Testing and inspection Center for Solar Energy Photovoltaic Products (Guangdong)



TEST REPORT

Random number: STJ4761

Page 1 of 16

Name of product	Crystalline silicon photovoltaic modules	Date of manufacturing/expiry	-----
Type/Specification	36V 210W, 36V 135W	Batch No.	-----
Inspected Unit	-----	No. of testing/sampling plan	257127
Address of inspected unit	-----	Test Type	Commision
Applicant	OVERSEA LIGHTING & ELECTRIC(M) SDN BHD	Sampling Location	-----
Factory	-----	Basic Quantity of Sampling	-----
Address of factory	-----	Way of sample incoming	-----/-----
Quantity of sample	4 pcs	Date of receipt of sample / sampling	2024-07-26
Status of sample	-----	Tested Date	2024-10-15
Testing reference	IEC 61215-2:2021 Terrestrial photovoltaic (PV) modules – Design qualification and type approval - Part 2: Test procedures		
Judgment reference	IEC 61215-2:2021 Terrestrial photovoltaic (PV) modules – Design qualification and type approval - Part 2: Test procedures		
Conclusion	This commission tested a total of 6 items: 1. Performance at STC see the test results; 2. All others meet the standard requirements.		
Notes	-----		

2024-10-15



Approved by:  Reviewed by:  Tested by: 

CERTIFICATE



深圳市计量质量检测研究院
Shenzhen Academy of Metrology & Quality Inspection

TEST REPORT

No.: WT213201404

Page 2 of 101 Pages

Sample Information:

Sample Description: Solar Charge Controller With Step-up LED Driver
Trade Mark: 
Model/Specification/Grade: SR-DM*** - X, SR-MES*** - X (***) can be 60, 80, 120, 160, 200, representing different load power of the product, X can be R, W, representing different communication modes)
Serial/Batch No. of Sample: -----
Manufactured Date: -----
Manufacture: SRNE Solar Co., Ltd
Manufacture Address: 4-5F, 13A Wutong Island, Neihuan Rd, Xixiang, Bao'an, SHENZHEN Guangdong
Factory: SRNE Solar Co., Ltd
Factory Address: Room 301, Building 5, Fuxing Road, No. 36, Chang'an Town, DONGGUAN CITY, Guangdong
Sample Quantity: 10PCS
Sample Description before Testing: Normal
Testing: ---

Client Information:

Applicant: SRNE Solar Co., Ltd
Applicant Address: 4-5F, 13A Wutong Island, Neihuan Rd, Xixiang, Bao'an, SHENZHEN Guangdong
Applicant Telephone: -----
Applicant Post Code: -----

Test Information:

Date of Receipt: 2021-07-28
Applicant No.: 8190575-1
Environment Condition: (25.4-27.0)°C, (48-68)%RH
Sample Method: Delivered by Applicant
Test Method(s): IEC/EN 62109-1:2010
Test Period: 2021-07-28 to 2021-08-20

Test Conclusion:

See inside page of report

Tested by: 陈官路 

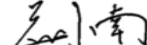
Checked by: 荆南 

CERTIFICATE



TEST REPORT IEC 62620 Secondary cells and batteries containing alkaline or other non-acid electrolytes - Secondary lithium cells and batteries for use in industrial applications	
Report Number.....	LCSA06074130S
Date of issue.....	2024-06-17
Total number of pages.....	19 pages
Applicant's name.....	OVERSEA LIGHTING & ELECTRIC (M) SDN BHD
Address.....	Lot 6595 & 6593, Jalan KPB 12B, Kawasan Industri Kg. Baru Balakong, 43300 Seri Kembangan, Selangor Darul Ehsan, Malaysia
Test specification:	
Standard.....	IEC 62620:2014
Test procedure.....	CB Scheme
Non-standard test method.....	N/A
Test Report Form No.	TRF-4-S-322 A/0
Test Report Form(s) Originator	KTL
Master TRF.....	Dated 2019-03-07
Copyright © 2019 IEC System of Conformity Assessment Schemes for Electrotechnical Equipment and Components (IECEE System). All rights reserved. This publication may be reproduced in whole or in part for non-commercial purposes as long as the IECEE is acknowledged as copyright owner and source of the material. IECEE takes no responsibility for and will not assume liability for damages resulting from the reader's interpretation of the reproduced material due to its placement and context.	
General disclaimer: The test results presented in this report relate only to the object tested. This report shall not be reproduced, except in full, without the written approval of Shenzhen LCS Compliance Testing Laboratory Ltd. The authenticity of this Test Report and its contents can be verified by contacting the Shenzhen LCS Compliance Testing Laboratory Ltd., responsible for this Test Report.	
Test item description.....	Lithium-ion Battery pack
Trade Mark.....	N/A
Manufacturer.....	Same as applicant
Model/Type reference.....	32135-8S4P
Ratings.....	25.6V, 60Ah, 1536Wh



Shenzhen LCS Compliance Testing Laboratory Ltd.
Add: 1-2F, Building A&B, Building C, Jiji Industrial Park, Yabianxueziwei, Shajing Street, Bao'an District, Shenzhen, Guangdong, China
Tel: +86 0755-82591330 | E-mail: webmaster@lcs-cert.com | Web: www.lcs-cert.com
Scan code to check authenticity



TEST REPORT IEC 62620 Secondary cells and batteries containing alkaline or other non-acid electrolytes - Secondary lithium cells and batteries for use in industrial applications	
Report Number.....	LCSA06074131S
Date of issue.....	2024-06-17
Total number of pages.....	19 pages
Applicant's name.....	OVERSEA LIGHTING & ELECTRIC (M) SDN BHD
Address.....	Lot 6595 & 6593, Jalan KPB 12B, Kawasan Industri Kg. Baru Balakong, 43300 Seri Kembangan, Selangor Darul Ehsan, Malaysia
Test specification:	
Standard.....	IEC 62620:2014
Test procedure.....	CB Scheme
Non-standard test method.....	N/A
Test Report Form No.	TRF-4-S-322 A/0
Test Report Form(s) Originator	KTL
Master TRF.....	Dated 2019-03-07
Copyright © 2019 IEC System of Conformity Assessment Schemes for Electrotechnical Equipment and Components (IECEE System). All rights reserved. This publication may be reproduced in whole or in part for non-commercial purposes as long as the IECEE is acknowledged as copyright owner and source of the material. IECEE takes no responsibility for and will not assume liability for damages resulting from the reader's interpretation of the reproduced material due to its placement and context.	
General disclaimer: The test results presented in this report relate only to the object tested. This report shall not be reproduced, except in full, without the written approval of Shenzhen LCS Compliance Testing Laboratory Ltd. The authenticity of this Test Report and its contents can be verified by contacting the Shenzhen LCS Compliance Testing Laboratory Ltd., responsible for this Test Report.	
Test item description.....	Lithium-ion Battery pack
Trade Mark.....	N/A
Manufacturer.....	Same as applicant
Model/Type reference.....	32135-8S6P
Ratings.....	25.6V, 90Ah, 2304Wh



Shenzhen LCS Compliance Testing Laboratory Ltd.
Add: 1-2F, Building A&B, Building C, Jiji Industrial Park, Yabianxueziwei, Shajing Street, Bao'an District, Shenzhen, Guangdong, China
Tel: +86 0755-82591330 | E-mail: webmaster@lcs-cert.com | Web: www.lcs-cert.com
Scan code to check authenticity

CERTIFICATE

Page 1 of 18 Report No.: LCSB07254049S

TEST REPORT

Of IES LM-79-19

Kunde: Client:	OVERSEA LIGHTING & ELECTRIC (M) SDN BHD		
Adresse: Address:	Lot 6595 & 6593, Jalan KP B 12B, Kawasan Industri Kg. Baru Balakong, 43300 Seri Kembangan, Selangor Darul Ehsan, Malaysia		
Hersteller: Manufacturer:	OVERSEA LIGHTING & ELECTRIC (M) SDN BHD		
Adresse: Address:	Lot 6595 & 6593, Jalan KP B 12B, Kawasan Industri Kg. Baru Balakong, 43300 Seri Kembangan, Selangor Darul Ehsan, Malaysia		
Name der Marke: Brand Name:	N/A		
Beschreibung des Produkts: Product Description:	Integrated solar street light		
Modelle: Models:	JKC-K-60W		
Bewertung: Rating:	DC42V, 60W		
Verfahren: Method:	IES LM-79-19: Approved Method for Electrical and Photometric Measurements of Solid-State Lighting Products		
Prüfergebnis: Test result:	Please see the following test data		
Datum der Prüfung: Date of Test:	Datum der Emission: Date of Issue:	Klassifizierung: Classification:	Gegenstand der Prüfung: Test Item:
2024-06-04-2024-06-06	2024-06-15	Commission Test	IES LM-79-19
Prüflabor (Testlabor) / Testing Laboratory: Shenzhen Southern LCS Compliance Testing Laboratory Ltd. Add: 101-201, No.39 Building, Xialang Industrial Zone, Heshuikou Community, Matian Street, Guangming District, Shenzhen, China.			
Compiled von/Compiled by:	Check von/Check by:	Genehmigt von/Approved by:	
<i>Zero Huang</i>	<i>Jan Luo</i>	<i>Jesse Liu</i>	
Zero Huang/ Project Engineer	Jan Luo/ Director	Jesse Liu/ Manager	
<small>Dieser Prüfbericht bezieht sich nur auf das o.g. Prüfmuster und darf ohne Genehmigung der Prüfstelle nicht auszugswise vervielfältigt werden. Dieser Bericht berechtigt nicht zur Verwendung eines Prüfzeichens. Remark: The duplication of this report or parts of it and its use for advertising purposes is only allowed with permission of the testing laboratory. This report contains the result of examination of the product sample submitted by the appliance. A general statement concerning the quality of the products from the series manufacturer cannot be derived therefore.</small>			

Form No:TRF-4-S-123 Ver. A/0



Page 1 of 18 Report No.: LCSB07254049S

TEST REPORT

Of IES LM-79-19

Kunde: Client:	OVERSEA LIGHTING & ELECTRIC (M) SDN BHD		
Adresse: Address:	Lot 6595 & 6593, Jalan KP B 12B, Kawasan Industri Kg. Baru Balakong, 43300 Seri Kembangan, Selangor Darul Ehsan, Malaysia		
Hersteller: Manufacturer:	OVERSEA LIGHTING & ELECTRIC (M) SDN BHD		
Adresse: Address:	Lot 6595 & 6593, Jalan KP B 12B, Kawasan Industri Kg. Baru Balakong, 43300 Seri Kembangan, Selangor Darul Ehsan, Malaysia		
Name der Marke: Brand Name:	N/A		
Beschreibung des Produkts: Product Description:	Integrated solar street light		
Modelle: Models:	JKC-K-80W		
Bewertung: Rating:	DC42V, 80W		
Verfahren: Method:	IES LM-79-19: Approved Method for Electrical and Photometric Measurements of Solid-State Lighting Products		
Prüfergebnis: Test result:	Please see the following test data		
Datum der Prüfung: Date of Test:	Datum der Emission: Date of Issue:	Klassifizierung: Classification:	Gegenstand der Prüfung: Test Item:
2024-06-04-2024-06-06	2024-06-15	Commission Test	IES LM-79-19
Prüflabor (Testlabor) / Testing Laboratory: Shenzhen Southern LCS Compliance Testing Laboratory Ltd. Add: 101-201, No.39 Building, Xialang Industrial Zone, Heshuikou Community, Matian Street, Guangming District, Shenzhen, China.			
Compiled von/Compiled by:	Check von/Check by:	Genehmigt von/Approved by:	
<i>Zero Huang</i>	<i>Jan Luo</i>	<i>Jesse Liu</i>	
Zero Huang/ Project Engineer	Jan Luo/ Director	Jesse Liu/ Manager	
<small>Dieser Prüfbericht bezieht sich nur auf das o.g. Prüfmuster und darf ohne Genehmigung der Prüfstelle nicht auszugswise vervielfältigt werden. Dieser Bericht berechtigt nicht zur Verwendung eines Prüfzeichens. Remark: The duplication of this report or parts of it and its use for advertising purposes is only allowed with permission of the testing laboratory. This report contains the result of examination of the product sample submitted by the appliance. A general statement concerning the quality of the products from the series manufacturer cannot be derived therefore.</small>			

Form No:TRF-4-S-123 Ver. A/0



Page 1 of 18 Report No.: LCSB07254008S

TEST REPORT

Of IES LM-79-19

Kunde: Client:	OVERSEA LIGHTING & ELECTRIC (M) SDN BHD		
Adresse: Address:	Lot 6595 & 6593, Jalan KP B 12B, Kawasan Industri Kg. Baru Balakong, 43300 Seri Kembangan, Selangor Darul Ehsan, Malaysia		
Hersteller: Manufacturer:	OVERSEA LIGHTING & ELECTRIC (M) SDN BHD		
Adresse: Address:	Lot 6595 & 6593, Jalan KP B 12B, Kawasan Industri Kg. Baru Balakong, 43300 Seri Kembangan, Selangor Darul Ehsan, Malaysia		
Name der Marke: Brand Name:	N/A		
Beschreibung des Produkts: Product Description:	Integrated solar street light		
Modelle: Models:	JKC-K-100W		
Bewertung: Rating:	DC48V, 100W		
Verfahren: Method:	IES LM-79-19: Approved Method for Electrical and Photometric Measurements of Solid-State Lighting Products		
Prüfergebnis: Test result:	Please see the following test data		
Datum der Prüfung: Date of Test:	Datum der Emission: Date of Issue:	Klassifizierung: Classification:	Gegenstand der Prüfung: Test Item:
2024-07-26	2024-07-29	Commission Test	IES LM-79-19
Prüflabor (Testlabor) / Testing Laboratory: Shenzhen Southern LCS Compliance Testing Laboratory Ltd. Add: 101-201, No.39 Building, Xialang Industrial Zone, Heshuikou Community, Matian Street, Guangming District, Shenzhen, China.			
Compiled von/Compiled by:	Check von/Check by:	Genehmigt von/Approved by:	
<i>Zero Huang</i>	<i>Jan Luo</i>	<i>Jesse Liu</i>	
Zero Huang/ Project Engineer	Jan Luo/ Director	Jesse Liu/ Manager	
<small>Dieser Prüfbericht bezieht sich nur auf das o.g. Prüfmuster und darf ohne Genehmigung der Prüfstelle nicht auszugswise vervielfältigt werden. Dieser Bericht berechtigt nicht zur Verwendung eines Prüfzeichens. Remark: The duplication of this report or parts of it and its use for advertising purposes is only allowed with permission of the testing laboratory. This report contains the result of examination of the product sample submitted by the appliance. A general statement concerning the quality of the products from the series manufacturer cannot be derived therefore.</small>			

TRF-4-S-123 A/0



Page 1 of 18 Report No.: LCSB07254009S

TEST REPORT

Of IES LM-79-19

Kunde: Client:	OVERSEA LIGHTING & ELECTRIC (M) SDN BHD		
Adresse: Address:	Lot 6595 & 6593, Jalan KP B 12B, Kawasan Industri Kg. Baru Balakong, 43300 Seri Kembangan, Selangor Darul Ehsan, Malaysia		
Hersteller: Manufacturer:	OVERSEA LIGHTING & ELECTRIC (M) SDN BHD		
Adresse: Address:	Lot 6595 & 6593, Jalan KP B 12B, Kawasan Industri Kg. Baru Balakong, 43300 Seri Kembangan, Selangor Darul Ehsan, Malaysia		
Name der Marke: Brand Name:	N/A		
Beschreibung des Produkts: Product Description:	Integrated solar street light		
Modelle: Models:	JKC-K-120W		
Bewertung: Rating:	DC48V, 120W		
Verfahren: Method:	IES LM-79-19: Approved Method for Electrical and Photometric Measurements of Solid-State Lighting Products		
Prüfergebnis: Test result:	Please see the following test data		
Datum der Prüfung: Date of Test:	Datum der Emission: Date of Issue:	Klassifizierung: Classification:	Gegenstand der Prüfung: Test Item:
2024-07-26	2024-07-29	Commission Test	IES LM-79-19
Prüflabor (Testlabor) / Testing Laboratory: Shenzhen Southern LCS Compliance Testing Laboratory Ltd. Add: 101-201, No.39 Building, Xialang Industrial Zone, Heshuikou Community, Matian Street, Guangming District, Shenzhen, China.			
Compiled von/Compiled by:	Check von/Check by:	Genehmigt von/Approved by:	
<i>Zero Huang</i>	<i>Jan Luo</i>	<i>Jesse Liu</i>	
Zero Huang/ Project Engineer	Jan Luo/ Director	Jesse Liu/ Manager	
<small>Dieser Prüfbericht bezieht sich nur auf das o.g. Prüfmuster und darf ohne Genehmigung der Prüfstelle nicht auszugswise vervielfältigt werden. Dieser Bericht berechtigt nicht zur Verwendung eines Prüfzeichens. Remark: The duplication of this report or parts of it and its use for advertising purposes is only allowed with permission of the testing laboratory. This report contains the result of examination of the product sample submitted by the appliance. A general statement concerning the quality of the products from the series manufacturer cannot be derived therefore.</small>			

TRF-4-S-123 A/0



CERTIFICATE

Page 1 of 18 Report No.:LCSB07254010S

TEST REPORT
Of IES LM-79-19

中国认可
国际互认
检测
TESTING
CNAS

Kunde: Client:	OVERSEA LIGHTING & ELECTRIC (M) SDN BHD		
Adresse: Address:	Lot 6595 & 6593, Jalan KP B 12B, Kawasan Industri Kg. Baru Balakong, 43300 Seri Kembangan, Selangor Darul Ehsan, Malaysia		
Hersteller: Manufacturer:	OVERSEA LIGHTING & ELECTRIC (M) SDN BHD		
Adresse: Address:	Lot 6595 & 6593, Jalan KP B 12B, Kawasan Industri Kg. Baru Balakong, 43300 Seri Kembangan, Selangor Darul Ehsan, Malaysia		
Name der Marke: Brand Name:	N/A		
Beschreibung des Produkts: Product Description:	integrated solar street light		
Modelle: Models:	JKC-K-150W		
Bewertung: Rating:	DC48V, 150W		
Verfahren: Method:	IES LM-79-19: Approved Method for Electrical and Photometric Measurements of Solid-State Lighting Products		
Prüfergebnis: Test result:	Please see the following test data		
Datum der Prüfung: Date of Test:	Datum der Emission: Date of Issue:	Klassifizierung: Classification:	Gegenstand der Prüfung: Test Item:
2024-07-26	2024-07-29	Commission Test	IES LM-79-19
Prüflabor (Testlabor) / Testing Laboratory: Shenzhen Southern LCS Compliance Testing Laboratory Ltd. Add: 101-201, No.39 Building, Xialang Industrial Zone, Heshuikou Community, Matian Street, Guangming District, Shenzhen, China.			
Compiled von/Compiled by:	Check von/Check by:	Genehmigt von/Approved by:	
Zero Huang	Jan Luo	Jesse Liu	
Zero Huang/ Project Engineer	Ian Luo/ Director	Jesse Liu/ Manager	
Dieser Prüfbericht bezieht sich nur auf das o.g. Prüfmuster und darf ohne Genehmigung der Prüfstelle nicht auszugswise vervielfältigt werden. Dieser Bericht berechtigt nicht zur Verwendung eines Prüfzeichens. Remark: The duplication of this report or parts of it and its use for advertising purposes is only allowed with permission of the testing laboratory. This report contains the result of examination of the product sample submitted by the appliance. A general statement concerning the quality of the products from the series manufacturer cannot be derived therefore.			

TRF-4-S-123 A/D

Shenzhen Southern LCS Compliance Testing Laboratory Ltd.
Add: 101-201, No.39 Building, Xialang Industrial Zone, Heshuikou Community, Matian Street, Guangming District, Shenzhen, China.
Tel: +86) 0755-82591330 | E-mail: webmaster@lcs-cert.com | Web: www.lcs-cert.com
Scan code to check authenticity

Page 1 of 18 Report No.:LCSB07254011S

TEST REPORT
Of IES LM-79-19

中国认可
国际互认
检测
TESTING
CNAS

Kunde: Client:	OVERSEA LIGHTING & ELECTRIC (M) SDN BHD		
Adresse: Address:	Lot 6595 & 6593, Jalan KP B 12B, Kawasan Industri Kg. Baru Balakong, 43300 Seri Kembangan, Selangor Darul Ehsan, Malaysia		
Hersteller: Manufacturer:	OVERSEA LIGHTING & ELECTRIC (M) SDN BHD		
Adresse: Address:	Lot 6595 & 6593, Jalan KP B 12B, Kawasan Industri Kg. Baru Balakong, 43300 Seri Kembangan, Selangor Darul Ehsan, Malaysia		
Name der Marke: Brand Name:	N/A		
Beschreibung des Produkts: Product Description:	integrated solar street light		
Modelle: Models:	JKC-F-120W		
Bewertung: Rating:	DC48V, 120W		
Verfahren: Method:	IES LM-79-19: Approved Method for Electrical and Photometric Measurements of Solid-State Lighting Products		
Prüfergebnis: Test result:	Please see the following test data		
Datum der Prüfung: Date of Test:	Datum der Emission: Date of Issue:	Klassifizierung: Classification:	Gegenstand der Prüfung: Test Item:
2024-07-26	2024-07-29	Commission Test	IES LM-79-19
Prüflabor (Testlabor) / Testing Laboratory: Shenzhen Southern LCS Compliance Testing Laboratory Ltd. Add: 101-201, No.39 Building, Xialang Industrial Zone, Heshuikou Community, Matian Street, Guangming District, Shenzhen, China.			
Compiled von/Compiled by:	Check von/Check by:	Genehmigt von/Approved by:	
Zero Huang	Jan Luo	Jesse Liu	
Zero Huang/ Project Engineer	Ian Luo/ Director	Jesse Liu/ Manager	
Dieser Prüfbericht bezieht sich nur auf das o.g. Prüfmuster und darf ohne Genehmigung der Prüfstelle nicht auszugswise vervielfältigt werden. Dieser Bericht berechtigt nicht zur Verwendung eines Prüfzeichens. Remark: The duplication of this report or parts of it and its use for advertising purposes is only allowed with permission of the testing laboratory. This report contains the result of examination of the product sample submitted by the appliance. A general statement concerning the quality of the products from the series manufacturer cannot be derived therefore.			

TRF-4-S-123 A/D

Shenzhen Southern LCS Compliance Testing Laboratory Ltd.
Add: 101-201, No.39 Building, Xialang Industrial Zone, Heshuikou Community, Matian Street, Guangming District, Shenzhen, China.
Tel: +86) 0755-82591330 | E-mail: webmaster@lcs-cert.com | Web: www.lcs-cert.com
Scan code to check authenticity

Page 1 of 18 Report No.:LCSB07254012S

TEST REPORT
Of IES LM-79-19

中国认可
国际互认
检测
TESTING
CNAS

Kunde: Client:	OVERSEA LIGHTING & ELECTRIC (M) SDN BHD		
Adresse: Address:	Lot 6595 & 6593, Jalan KP B 12B, Kawasan Industri Kg. Baru Balakong, 43300 Seri Kembangan, Selangor Darul Ehsan, Malaysia		
Hersteller: Manufacturer:	OVERSEA LIGHTING & ELECTRIC (M) SDN BHD		
Adresse: Address:	Lot 6595 & 6593, Jalan KP B 12B, Kawasan Industri Kg. Baru Balakong, 43300 Seri Kembangan, Selangor Darul Ehsan, Malaysia		
Name der Marke: Brand Name:	N/A		
Beschreibung des Produkts: Product Description:	integrated solar street light		
Modelle: Models:	JKC-F-150W		
Bewertung: Rating:	DC48V, 150W		
Verfahren: Method:	IES LM-79-19: Approved Method for Electrical and Photometric Measurements of Solid-State Lighting Products		
Prüfergebnis: Test result:	Please see the following test data		
Datum der Prüfung: Date of Test:	Datum der Emission: Date of Issue:	Klassifizierung: Classification:	Gegenstand der Prüfung: Test Item:
2024-07-26	2024-07-29	Commission Test	IES LM-79-19
Prüflabor (Testlabor) / Testing Laboratory: Shenzhen Southern LCS Compliance Testing Laboratory Ltd. Add: 101-201, No.39 Building, Xialang Industrial Zone, Heshuikou Community, Matian Street, Guangming District, Shenzhen, China.			
Compiled von/Compiled by:	Check von/Check by:	Genehmigt von/Approved by:	
Zero Huang	Jan Luo	Jesse Liu	
Zero Huang/ Project Engineer	Ian Luo/ Director	Jesse Liu/ Manager	
Dieser Prüfbericht bezieht sich nur auf das o.g. Prüfmuster und darf ohne Genehmigung der Prüfstelle nicht auszugswise vervielfältigt werden. Dieser Bericht berechtigt nicht zur Verwendung eines Prüfzeichens. Remark: The duplication of this report or parts of it and its use for advertising purposes is only allowed with permission of the testing laboratory. This report contains the result of examination of the product sample submitted by the appliance. A general statement concerning the quality of the products from the series manufacturer cannot be derived therefore.			

TRF-4-S-123 A/D

Shenzhen Southern LCS Compliance Testing Laboratory Ltd.
Add: 101-201, No.39 Building, Xialang Industrial Zone, Heshuikou Community, Matian Street, Guangming District, Shenzhen, China.
Tel: +86) 0755-82591330 | E-mail: webmaster@lcs-cert.com | Web: www.lcs-cert.com
Scan code to check authenticity

CERTIFICATE



No Lesen : PC001687

Licence No :

LESEN PENSIJILAN BARANGAN *Product Certification Licence*



SIRIM QAS International Sdn. Bhd. dengan ini menganugerahkan kepada
SIRIM QAS International Sdn. Bhd. hereby grants to

OVERSEA LIGHTING & ELECTRIC (M) SDN. BHD.
LOT 6595, JALAN KPB 12B
KAWASAN INDUSTRI
KAMPUNG BARU BALAKONG
43300 SERI KEMBANGAN
SELANGOR, MALAYSIA



ACB 001

Lesen untuk menggunakan Tanda Pensijilan di atas barangan
a licence to use the Certification Mark on

LED LUMINAIRES FOR ROAD AND STREET LIGHTING

Please refer to detail in the SCHEDULE



sebagai mematuhi keperluan
as complying with

MS IEC 60598-1 : 2012
MS IEC 60598-2-3 : 1997

Nur Fadhilah binti Muhammad
Ketua Pegawai Eksekutif
Chief Executive Officer
SIRIM QAS International Sdn. Bhd.



SIRIM QAS International Sdn. Bhd.
(No. Syarikat 199601037981(410334-X))

1, Persiaran Dato' Menteri
Seksyen 2, Peti Surat 7035
40700 Shah Alam
Selangor Darul Ehsan
MALAYSIA.

Tel : 603-5544 6000
Emel : cserviceqas@sirim.my

<https://www.sirim-qas.com.my>
<https://www.malysiancertified.com.my>

Tarikh Mula Pensijilan : 10 April 2015

Certified Since

Sah Sehingga : 10 April 2025

Valid Until

Lesen ini dianugerahkan tertakluk kepada syarat-syarat Perjanjian Pensijilan Barangan SIRIM QAS International Sdn. Bhd.
This Licence is granted subject to the provisions of the Product Certification Agreement of SIRIM QAS International Sdn. Bhd.

Tarikh Dikeluarkan : 20 February 2024

Issue Date

No Siri : 095015

Serial No

CERTIFICATE



No Lesen : **PC014384**

Licence No :

SCHEDULE

OVERSEA LIGHTING & ELECTRIC (M) SDN. BHD.



Trade Mark : OLE
Model : JKC-F-120W
Rating : 36Vdc, 120W, 210Ah, CCT 3500K, IP65, Class III, ta=45°C
Type : Integrated Solar Street Lantern
Size : 1720*975*60mm
Product tested to IEC 60589-2-3:2002+A1:2011 used in conjunction with IEC 60598-1:2020



Trade Mark : OLE
Model : JKC-F-150W
Rating : 36Vdc, 150W, 270Ah, CCT 3500K, IP65, Class III, ta=45°C
Type : Integrated Solar Street Lantern
Size : 2150*975*60mm
Product tested to IEC 60589-2-3:2002+A1:2011 used in conjunction with IEC 60598-1:2020



Trade Mark : OLE
Model : JKC-K-100W
Rating : 36Vdc, 100W, 75Ah, CCT 3500K, IP65, Class III, ta=45°C
Type : Integrated Solar Street Lantern
Size : 1930*600*60mm
Product tested to IEC 60589-2-3:2002+A1:2011 used in conjunction with IEC 60598-1:2020

Trade Mark : OLE
Model : JKC-K-150W
Rating : 36Vdc, 150W, 150Ah, CCT 3500K, IP65, Class III, ta=45°C
Type : Integrated Solar Street Lantern
Size : 1755*970*60mm
Product tested to IEC 60589-2-3:2002+A1:2011 used in conjunction with IEC 60598-1:2020

Trade Mark : OLE
Model : JKC-K-60W
Rating : 36Vdc, 60W, 45Ah, CCT 3500K, IP65, Class III, ta=45°C
Type : Integrated Solar Street Lantern
Size : 1800*410*60mm
Product tested to IEC 60589-2-3:2002+A1:2011 used in conjunction with IEC 60598-1:2020

SIRIM QAS International Sdn. Bhd.
(No. Syarikat 199601037981(410334-X))

1, Persiaran Dato' Menteri
Seksyen 2, Peti Surat 7035
40700 Shah Alam
Selangor Darul Ehsan
MALAYSIA.

Tel : 603-5544 6000
Emel : cserviceqas@sirim.my

<https://www.sirim-qas.com.my>
<https://www.malaysiancertified.com.my>

Tarikh Mula Pensijilan : **02 January 2025**

Certified Since

Sah Sehingga : **02 January 2026**

Valid Until

Tarikh Dikeluarkan : **02 January 2025**

Issue Date

No Siri : 106503

Serial No

Lesen ini dianugerahkan tertakluk kepada syarat-syarat Perjanjian Pensijilan Barangan SIRIM QAS International Sdn. Bhd.
This Licence is granted subject to the provisions of the Product Certification Agreement of SIRIM QAS International Sdn. Bhd.

CERTIFICATE



No Lesen : **PC014384**

Licence No :

SCHEDULE

OVERSEA LIGHTING & ELECTRIC (M) SDN. BHD.



Trade Mark : OLE
Model : JKC-K-80W
Rating : 36Vdc, 80W, 60Ah, CCT 3500K, IP65, Class III, ta=45°C
Type : Integrated Solar Street Lantern
Size : 1750*385*60mm
Product tested to IEC 60589-2-3:2002+A1:2011 used in conjunction with IEC 60598-1:2020



Trade Mark : OLE
Model : JKC-K-120W
Rating : 36Vdc, 120W, 90Ah, CCT 3500K, IP65, Class III, ta=45°C
Type : Integrated Solar Street Lantern
Size : 1930*600*60mm
Product tested to IEC 60589-2-3:2002+A1:2011 used in conjunction with IEC 60598-1:2020



End of page

SIRIM QAS International Sdn. Bhd.
(No. Syarikat 199601037981(410334-X))

1, Persiaran Dato' Menteri
Seksyen 2, Peti Surat 7035
40700 Shah Alam
Selangor Darul Ehsan
MALAYSIA.

Tel : 603-5544 6000
Emel : cserviceqas@sirim.my

<https://www.sirim-qas.com.my>
<https://www.malysiancertified.com.my>

Tarikh Mula Pensijilan : 02 January 2025

Certified Since

Sah Sehingga : 02 January 2026

Valid Until

Lesen ini dianugerahkan tertakuk kepada syarat-syarat Perjanjian Pensijilan Barangan SIRIM QAS International Sdn. Bhd.
This Licence is granted subject to the provisions of the Product Certification Agreement of SIRIM QAS International Sdn. Bhd.

Tarikh Dikeluarkan : 02 January 2025

Issue Date

No Siri : 106503

Serial No

CERTIFICATE



SIRIM QAS International Sdn. Bhd.
(Company No.: 199601037981 (410334-X))
No.1, Persiaran Dato' Menteri, P.O.BOX 7035, Section 2,
40700 Shah Alam, Selangor Darul Ehsan, Malaysia
Tel: 03-55100461
Fax: 03-55446796
www.sirim-qas.com.my



TEST REPORT

REPORT NO : 2022EB0286

PAGE : 1 OF 12

This Test Report refers only to samples submitted by the applicant to SIRIM QAS International Sdn. Bhd. and tested by SIRIM QAS International Sdn. Bhd. This Test Report shall not be reproduced, except in full and shall not be used for any purpose by any means or forms (including but not limited to advertising purposes) without written approval from the Head of Quality, Occupational Safety and Health & Environment (QOSHE), SIRIM QAS International Sdn. Bhd. Please refer to the last page of this Test Report for Conditions Relating to the Use of Test Report.

THIS TEST REPORT IS ISSUED IN SECURED PDF SOFTCOPY

Applicant : Oversea Lighting & Electric (M) Sdn. Bhd.,
Lot 6595, Jalan KPB12B,
Kawasan Industri Kg. Baru Balakong,
43300 Seri Kembangan, Selangor, MALAYSIA.

Manufacturer : Oversea Lighting & Electric (M) Sdn. Bhd.,
Lot 6595, Jalan KPB12B,
Kawasan Industri Kg. Baru Balakong,
43300 Seri Kembangan, Selangor, MALAYSIA.

Product : Integrated Solar LED Street Light

Reference Standard / Method of Test : IES LM 79-08
(Electrical and Photometric Measurement of Solid-State Lighting Product)

Description of sample : Brand Name : OLE Luminaires
Model / Type : OLE-JKC-K-120W
Rating
Voltage : 25.6 Vdc (Battery)
Power : 120 W
Luminous flux : 20,160 lm
Luminous Efficacy : 168 lm/W
CCT : 3500 K

Date Received of Complete Application : 12 April 2022

Job No. : J20222120187

Description of Test Results : (See Appendix)

Issued Date : 24 June 2022

Approved Signatory;

(NOR AZLINA BINTI MUSLIM)
Senior Testing Executive



(SHARIFAH BINTI JUSOH)
Head
Electrical & Electronics 2 Section
Testing Services Department

CERTIFICATE



No Lesen : **PC002490**

Licence No :

LESEN PENSIJILAN BARANGAN *Product Certification Licence*



**SIRIM QAS International Sdn. Bhd. dengan ini menganugerahkan kepada
*SIRIM QAS International Sdn. Bhd. hereby grants to***

**OVERSEA LIGHTING & ELECTRIC (M) SDN. BHD.
LOT 6595, JALAN KP B 12B
KAWASAN INDUSTRI
KAMPUNG BARU BALAKONG
43300 SERI KEMBANGAN
SELANGOR, MALAYSIA**

**Lesen untuk menggunakan Tanda Pensijilan di atas barangan
*a licence to use the Certification Mark on***

STEEL LIGHTING COLUMN

Please refer to detail in the SCHEDULE

**sebagai mematuhi keperluan
*as complying with***

BS EN 40-5 : 2002

Nur Fadhilah binti Muhammad
Ketua Pegawai Eksekutif
Chief Executive Officer
SIRIM QAS International Sdn. Bhd.



SIRIM QAS International Sdn. Bhd.
(No. Syarikat 199601037981(410334-X))

1, Persiaran Dato' Menteri
Seksyen 2, Peti Surat 7035
40700 Shah Alam
Selangor Darul Ehsan
MALAYSIA.

Tel : 603-5544 6000
Emel : cserviceqas@sirim.my

<https://www.sirim-qas.com.my>
<https://www.malaysiancertified.com.my>

Tarikh Mula Pensijilan : 26 August 2016

Certified Since

Sah Sehingga : 26 August 2025

Valid Until

Lesen ini dianugerahkan tertakluk kepada syarat-syarat Perjanjian Pensijilan Barangan SIRIM QAS International Sdn. Bhd.
This Licence is granted subject to the provisions of the Product Certification Agreement of SIRIM QAS International Sdn. Bhd.

Tarikh Dikeluarkan : 22 August 2024

Issue Date

No Siri : 101717

Serial No

CERTIFICATE



No Lesen : PC002490

Licence No :

SCHEDULE

OVERSEA LIGHTING & ELECTRIC (M) SDN. BHD.



Trade Mark : OLE
Model : OLE PL TP0001-0000
Rating : CLASS 0
Type : FLANGE MOUNTED TYPE WITH CIRCULAR CROSS SECTION AND REINFORCED DEFORMED BAR
Size : UP TO AND INCLUDING HEIGHT of 12 m
GALVANISED COATING COLUMN WITH STEEL SERVICE DOOR

Trade Mark : OLE
Model : OLE PL OF0001-0000
Rating : CLASS 0
Type : FLANGE MOUNTED TYPE WITH OCTAGONAL CROSS SECTION
Size : UP TO AND INCLUDING HEIGHT of 12 m
GALVANISED COATING COLUMN WITH STEEL SERVICE DOOR

Trade Mark : OLE
Model : OLE PL OP0001-0000
Rating : CLASS 0
Type : PLANTED TYPE WITH OCTAGONAL CROSS SECTION
Size : UP TO AND INCLUDING HEIGHT of 12 m
GALVANISED COATING COLUMN WITH STEEL SERVICE DOOR

End of page

SIRIM QAS International Sdn. Bhd.
(No. Syarikat 199601037981(410334-X))

1, Persiaran Dato' Menteri
Seksyen 2, Peti Surat 7035
40700 Shah Alam
Selangor Darul Ehsan
MALAYSIA.

Tel : 603-5544 6000
Emel : cserviceqas@sirim.my

<https://www.sirim-qas.com.my>
<https://www.malaysiancertified.com.my>

Tarikh Mula Pensijilan : 26 August 2016

Certified Since

Sah Sehingga : 26 August 2025

Valid Until

Tarikh Dikeluarkan : 22 August 2024

Issue Date

No Siri : 101717

Serial No

Lesen ini dianugerahkan tertakluk kepada syarat-syarat Perjanjian Pensijilan Barangan SIRIM QAS International Sdn. Bhd.
This Licence is granted subject to the provisions of the Product Certification Agreement of SIRIM QAS International Sdn. Bhd.

CERTIFICATE

No. Siri : EE022003/21/10/01



Ruj Kami : (94) dlm. JKRL (PM)5/1/4-14 Jld.9

CAWANGAN KEJURUTERAAN ELEKTRIK JABATAN KERJA RAYA MALAYSIA

SIJIL EMAL

Sijil Pendaftaran Bahan/Barangan Elektrik (Electrical Material Approved List) ini dikeluarkan kepada **pengilang/pembekal** :

Syarikat : **OVERSEA LIGHTING & ELECTRIC (M) SDN. BHD.**
Alamat : LOT 6595, JALAN KPB12B, KAWASAN INDUSTRI KAMPUNG BARU BALAKONG,
43300 SERI KEMBANGAN, SELANGOR

Bahan : **LIGHTING COLUMNS (HOT DIP GALVANIZED STEEL)**

Pendaftaran ini adalah seperti butiran di bawah dan tertakluk kepada Spesifikasi JKR dan **syarat-syarat di muka surat 2.**

Pengilang	: OVERSEA LIGHTING & ELECTRIC (M) SDN. BHD.
Negara Pengilang	: MALAYSIA
No. Telefon Syarikat	: 03-89641878
No. Faksimili Syarikat	: 03-89641868
Emel Syarikat	: info@oversealighting.com
Jenama	: OLE
Model	: PLANTED AND FLANGED MOUNTED
Ketinggian	: UP TO 12 METER
No. Perakuan ST/No. Sijil/	: SIJIL SIRIM : PC002490
Laporan Ujian Jenis	: LAPORAN UJIAN SIRIM : 2016MA0848
Tarikh Tamat	: 15.10.2024
Rujukan Standard	: BS EN 40-5:2002
Catatan	: SERVICE DOOR HENDAKLAH DARI JENIS FIBREGLASS MENGUNAKAN DOUBLE SLOT HINGE.

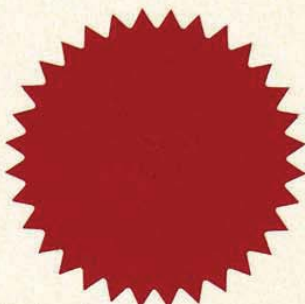

Tarikh dikeluarkan/diperbaharui : 20 Oktober 2021

Ir. HANIZAN BINTI SHAFFII
Pengarah Kanan
Cawangan Kejuruteraan Elektrik
b.p Ketua Pengarah Kerja Raya
JKR Malaysia

PROJECT PHOTO



OLE Solar JKC-K with mid hinge pole at Johor, Malaysia



OLE Solar at Sg Karas, Labis, Johor, Malaysia



OLE Solar JKC F 150W at Alam Sutera, Bukit Jalil, DBKL



OLE Solar JKC-K 80W with mid hinge pole at Taman Tasik Sri Gombak, Batu Caves

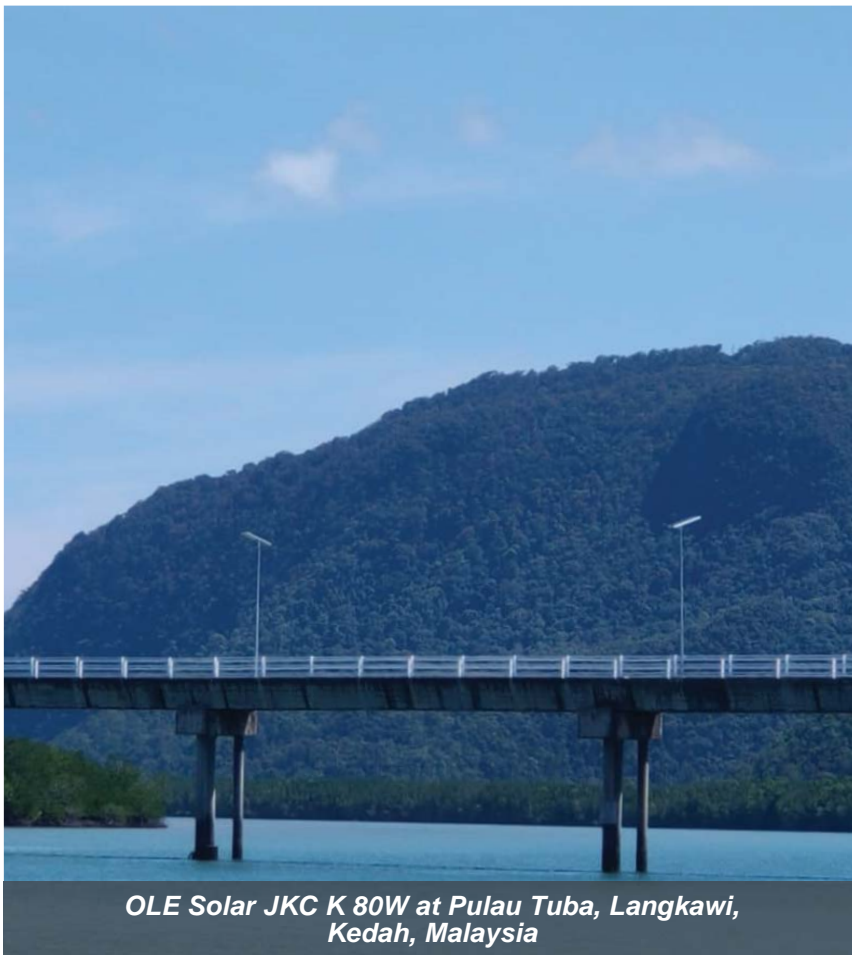

OLE Solar JKC K 80W at Pulau Tuba, Langkawi, Kedah, Malaysia



OLE Solar JKC K 80W at Pulau Tuba, Langkawi, Kedah, Malaysia

PROJECT PHOTO



OLE Solar JKC-KM at Pengerang, Johor, Malaysia



OLE Solar JKC-KM at Cheras, Selangor, Malaysia



OLE Solar JKC-K at Alam Sutera, Bukit Jalil, Malaysia



OLE Solar JKC-KM at Cheras, Selangor, Malaysia



OLE Solar JKC-K 120W at Jalan Ban Foo, Ulu Tiram, Johor, Malaysia



OLE Solar JKC-K 100W at Rumah Pelangi Kg Bodor, Kota Bharu, Kelantan



OLE Solar JKC-F 150W with mid hinge pole



OLE Solar JKC-K 120W at Langkasuka, Larkin, Johor, Malaysia

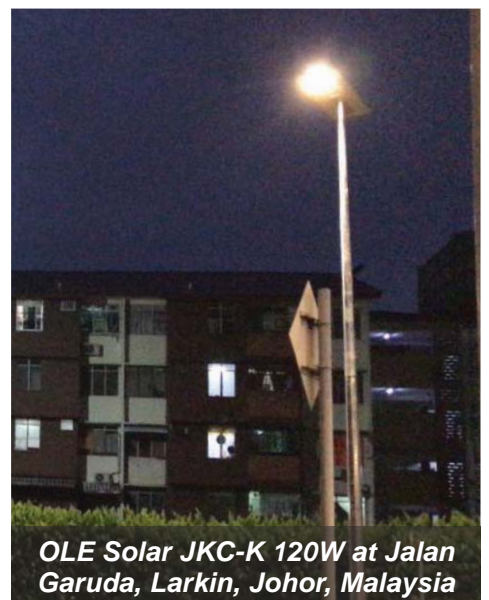

OLE Solar JKC-K 120W at Jalan Garuda, Larkin, Johor, Malaysia

***OVERSEA LIGHTING & ELECTRIC (M) SDN. BHD.
(272782-K)***



LED Factory

Lot 6595, Jalan KPB 12B,
Kawasan Industri Kampung Baru Balakong,
43300 Seri Kembangan,
Selangor Darul Ehsan, Malaysia.

Tel: 603-8964 1878, 8964 1888, 8964 1899
Fax: 603-8964 1868
Email: info@oversealighting.com
Website: www.oversealighting.com

Pole Factory

PT 3481 (Lot 996), Jalan Sungai Lalang, Batu 22 1/2,
43500 Semenyih, Selangor Darul Ehsan, Malaysia.

Tel: 03-95493440/ 012-8377850
Email: general.odi@outlook.com

Oversea Lighting & Electric (M) Sdn Bhd reserves the right to make changes in specifications and/ or to discontinue any product at any time without notice.